



METER

AQUALAB 3



TABLE OF CONTENTS

1. Introduction.....	1
2. Operation	3
2.1 System Network Requirements	3
2.1.1 Connection Options	5
2.1.2 NEXUS Static IP Address.....	5
2.1.3 Using a METER Data Logger	6
2.2 AQUALAB 3 First Time Setup	6
2.2.1 Connect AQUALAB 3 and NEXUS	7
2.2.2 Connect iPad and Download SKALA Mobile App	8
2.2.3 Register New Company Site	9
2.2.4 Connect First NEXUS	13
2.2.5 Enter SKALA Mobile First Time	15
2.2.6 Create First Product.....	16
2.3 Enter Existing Company Site.....	19
2.3.1 Add Additional iPads to Existing System	20
2.3.2 Add Additional NEXUSES	21
2.3.3 Add Additional Water Activity Products	23
2.3.4 Select Market Groups (Subscription Required).....	28
2.3.5 Add First Total Moisture Product (Subscription Required).....	31
2.4 Add a Batch.....	35
2.5 Take a Reading	38
2.5.1 Water Activity Reading.....	39
2.5.2 Total Moisture Reading	46
2.5.3 One-Minute Water Activity Reading Mode	54

3. System	55
3.1 Specifications.....	55
3.2 Components	56
3.2.1 Sensor Block.....	57
3.2.2 Sample Drawer	58
3.2.3 Drawer Knob Indicator Lights.....	59
3.2.4 NEXUS	60
3.3 Modes and Tests	61
3.3.1 One-Minute Water Activity Mode.....	61
3.3.2 Total Moisture	62
3.4 Theory.....	62
3.4.1 Water Content.....	62
3.4.2 Moisture Content	63
4. Service	67
4.1 Performance Verification	67
4.2 Cleaning.....	70
4.3 Troubleshooting.....	73
4.4 Customer Support.....	75
4.5 Terms and Conditions	75
References	76

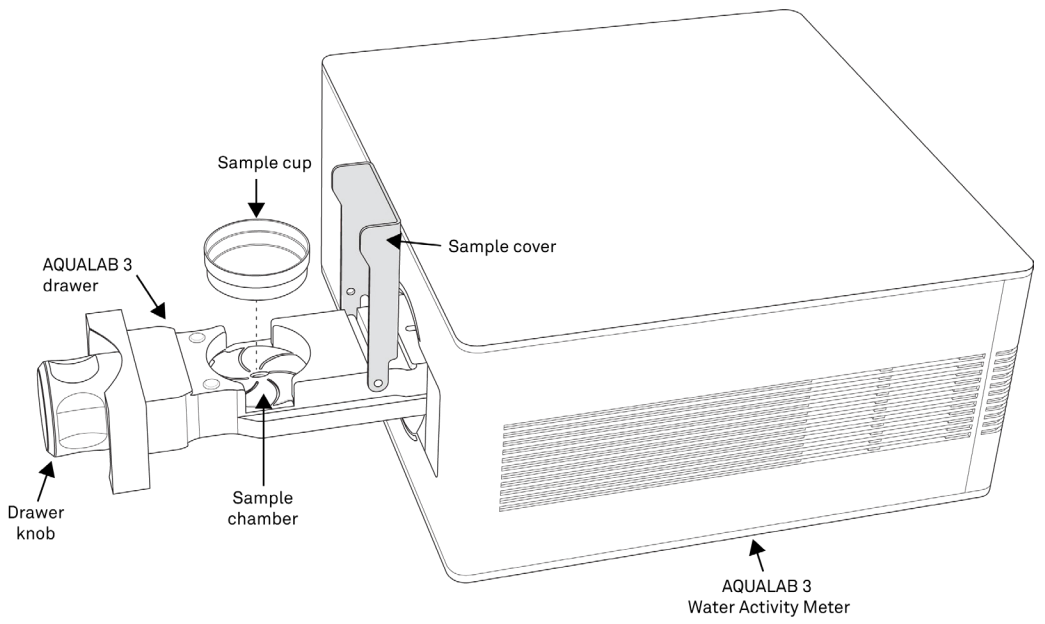

1. INTRODUCTION

Thank you for choosing the AQUALAB® 3 water activity meter from METER Group. The AQUALAB 3 uses a chilled-mirror dew point sensor and capacitive hygrometer and is controlled and operated through the SKALA® Mobile by METER application using an Apple® iPad® device.

Verify all AQUALAB 3 system components are included and appear in good condition:

- AQUALAB 3 Water Activity Meter with calibrated sensor block
- AQUALAB Accessory Kit
 - ◆ Standards kit
 - ◆ Cleaning kit
 - ◆ SDS booklet
 - ◆ Power cable, 2.29 m (7.5 ft)
 - ◆ USB A to USB B cable, 1.83 m (6 ft)
- SKALA NEXUS Benchtop Unit
- SKALA NEXUS Accessory Kit
 - ◆ AC adapter (micro USB)
 - ◆ Ethernet cable, 1.83 m (6 ft)
 - ◆ USB A to USB B cable 0.81 m (2.66 ft)
- iPad stand
- Apple iPad (optional)

NOTE: Prior models of AQUALAB 3 are compatible with a SKALA Hub. If setup assistance with a SKALA Hub is needed, please contact [Customer Support](#).

SKALA Mobile by METER, an application available from the Apple App Store, will need to be downloaded onto the iPad. The app is used to register a new customer site, create products and batches, and operate the equipment. Everything that is created in SKALA Mobile is stored in the SKALA Control cloud service.

SKALA Control is a cloud-based software program where data can be analyzed and downloaded and where more advanced settings can be made. SKALA Control stores all historic readings, displays readings in charts, modifies customer site settings and users, modifies existing tests, plus much more.

Freemium version. The first time a customer site is set up, there is no charge for the use of basic features available in the SKALA Mobile app (referred to as Freemium). In the Freemium version, only water activity features are available.

Subscriptions. Monthly SKALA Control subscriptions are needed to utilize additional features such as total moisture readings ([Section 2.5.2](#)) and one-minute reading mode ([Section 2.5.3](#)). To learn more about SKALA Control subscription plans, go to metergroup.com/skala-upgrade or contact [Customer Support](#).

SKALA training [documents](#) and [videos](#) can assist when learning how to use SKALA Control.

For more information on SKALA Control, please contact [Customer Support](#).

2. OPERATION

Please read all instructions before operating the SKALA Mobile app and the AQUALAB 3 meter to ensure everything performs to its full potential.

Please observe the following considerations carefully.

- Only allow personnel who have been qualified by METER to carry out service work on the electrical components.
- Only operate this instrument with the main power voltage specified (100 to 240 VAC at 50 to 60 Hz).
- Plug the instrument into a grounded outlet or power strip.
- Only use the fuse type and rating specified for this instrument ([Section 3.1](#)).
If the instrument is used in a manner not specified by the manufacturer, the protection provided by the equipment may be impaired.

PRECAUTIONS

METER products are built to the highest standards, but misuse, improper protection, or improper installation may damage the meter and possibly void the manufacturer's warranty. Before using the AQUALAB 3, follow the recommended setup instructions and arrange proper protections to safeguard the instrument from damage.

2.1 SYSTEM NETWORK REQUIREMENTS

METER Group recommends the following as the network requirements for the SKALA deployment environment (the environment where the NEXUS and Apple® iPad® mobile digital device are installed). Implement the security controls that are appropriate for the sensitivity of the data.

- Internet connection—standard 1 GbE network or faster.
- The devices must be able to connect to the following destinations using the same network:
 - ♦ skalacontrol.com—the primary endpoint for the SKALA server, hosted by METER Group.
 - ♦ websocket.skalacontrol.com—the functional endpoint for the websocket communications layer.
 - ♦ *.zoho.com—utilized for the METER secure remote support tool.
 - ♦ *.skalanexus.com—connection between the iPad and the NEXUS.
- The iPad and NEXUS devices must be able to communicate over the ports listed in the following table. METER typically recommends placing them on the same subnet to easily facilitate communication. However, if the network team desires, utilizing a network address translation (NAT) to bridge subnets is acceptable.

The following table lists the ports that must be available for the SKALA system to function properly.

AQUALAB 3

Port	Direction	Destination	Usage
80	In/Out	PIP/DPKG sources	System and package updates
443	In/Out	skalacontrol.com websockets.skalacontrol.com	HTTPS over TLS communication, used to retrieve and post data to the SKALACONTROL server
443	In/Out	*.zoho.com	Utilized for the METER remote support tools, enables the METER team to help and resolve issues and outages
123	In/Out	NTP provider	Used for NTP timy sync
3128	In/Out	PIP	System and package updates
9001	In/Out	*.skalanexus.com	Used for secure communication between the iPad and NEXUS devices. Communication is made utilizing unicast via a known IP address.

The following diagram illustrates the network connections and communications protocols.

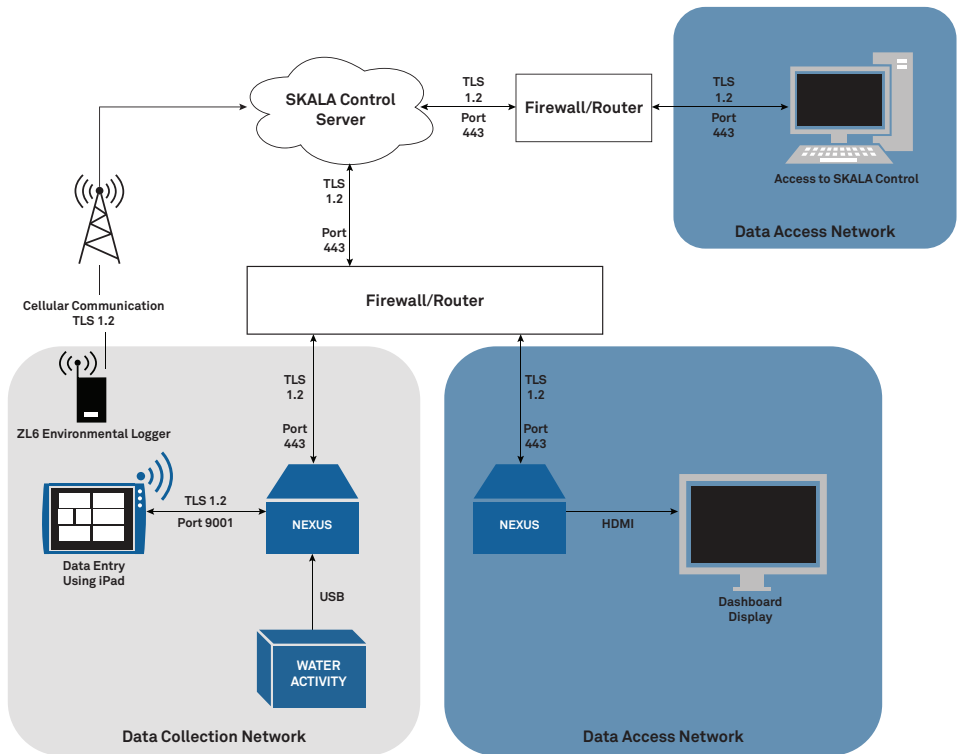

2.1.1 CONNECTION OPTIONS

The Apple iPad and/or PC has to be able to communicate with the NEXUS via the user's internal network. It doesn't matter whether the different components are connected via a Wi-Fi® connection or Ethernet cable, respectively.

AQUALAB 3

AQUALAB 3 always connects to the NEXUS via a USB A to B cable.

APPLE IPAD

The Apple iPad connects to the network via a Wi-Fi connection or via an Ethernet cable through a lightning port-to-Ethernet adapter.

The iPad can also connect to the network via the NEXUS. To do this, please connect the iPad to the NEXUS using the following configuration:

lightning-to-Ethernet adapter → Ethernet cable → USB-to-Ethernet adapter

NEXUS

METER recommends connecting the NEXUS to the network via an Ethernet cable. Connecting the NEXUS to WiFi can be configured using the USB-to-USB cable (included) and the NEXUS Utility software (available at metergroup.com/food/downloads/).

PC INSTEAD OF IPAD

The user will take readings via <https://skalacontrol.io> accessed from the user's PC web browser. The PC can connect to either Wi-Fi or Ethernet for a nominal fee.

SKALA CONTROL

SKALA Control is accessible at <https://skalacontrol.com/> via a web browser. METER recommends using Google Chrome for the best possible user experience.

2.1.2 NEXUS STATIC IP ADDRESS

To allow for encrypted communication between the iPad and the NEXUS, METER registers a subdomain pointing to the local IP address of the NEXUS. The iPad will connect to the NEXUS via *.skalanexus.com. If the local IP address changes, it could take between 5 min and a few hours for the DNS update to be propagated to the customer DNS server. During this time, the iPad will not be able to communicate with the NEXUS.

To prevent the local IP address from changing, follow these recommendations:

- Use a static IP address for every NEXUS
- Refrain from switching between Wi-Fi® and Ethernet interfaces

If changing the NEXUS local IP address cannot be avoided, Cloudflare® can be used to help changes propagate quickly. Both the iPad or Windows® PC can be set to use Cloudflare as the DNS server.

To set Cloudflare as the DNS server on an Apple iPad (iOS), use the following steps:

1. Navigate to Settings
2. Select Wi-Fi
3. Select the i icon next to the Wi-Fi network in use
4. Press Configure DNS
5. Choose Manual
6. Press Add Server
7. Add the server 1.1.1.1
8. Select Save

To set Cloudflare as the DNS server on a Windows PC (Windows 10), follow [these instructions \(privateinternetaccess.com/blog/changing-your-dns-settings-on-windows-10\)](https://privateinternetaccess.com/blog/changing-your-dns-settings-on-windows-10).

2.1.3 USING A METER DATA LOGGER

METER data loggers do not require a Wi-Fi network or Ethernet. The data loggers have an LTE cellular modem that connects directly to METER cloud services. The loggers operate with T-Mobile® and AT&T® cellular carriers and usually find a good signal. If the location is notorious for poor cell coverage, inform METER so other hardware solutions can be considered.

Please review the network requirements prior to the arrival of a member of METER Professional Services to ensure a smooth, quick, and efficient installation process.

2.2 AQUALAB 3 FIRST TIME SETUP

Place the AQUALAB 3 on a clean, level surface in a location where the ambient temperature remains relatively constant.

NOTE: The AQUALAB 3 should be positioned well away from all heating and air-conditioning vents, open windows, outside doors, refrigerator exhausts, and other sources of temperature fluctuation.

This section explains how to connect the AQUALAB 3 and the NEXUS ([Section 2.2.1](#)), connect the iPad device to a local Wi-Fi® network and download the SKALA Mobile app to the iPad device ([Section 2.2.2](#)), register a new company site ([Section 2.2.3](#)), connect and verify the first NEXUS ([Section 2.2.4](#)), enter SKALA Mobile the first time ([Section 2.2.5](#)), and set up the first product ([Section 2.2.6](#)).

2.2.1 CONNECT AQUALAB 3 AND NEXUS

The steps below explain how to connect the AQUALAB 3 and the NEXUS (Figure 1).

1. Plug the AQUALAB 3 power cable into the back of the AQUALAB 3 and into a grounded outlet or power strip.
2. Plug the NEXUS power cable into the micro USB port on the side of the NEXUS and into a grounded outlet or power strip.
3. Plug the USB A connector of the USB A to B cable into the USB A port on the NEXUS.
4. Plug the USB B connector of the USB A to B cable into the USB B port on the AQUALAB 3.
5. Plug the Ethernet cable into the NEXUS and into an Ethernet wall jack.

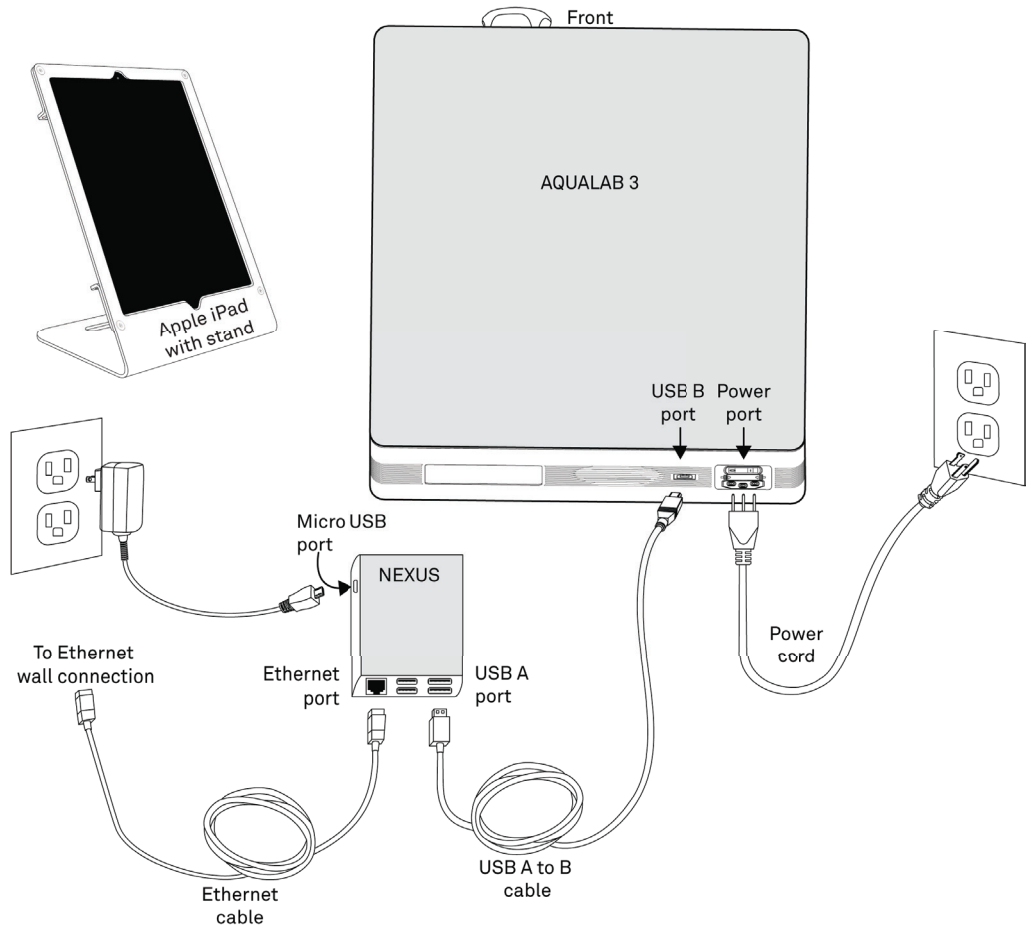

Figure 1 AQUALAB 3 system

Please see System Network Requirements for additional setup information.

2.2.2 CONNECT IPAD AND DOWNLOAD SKALA MOBILE APP

The steps below explain how to connect the iPad (Figure 2) to the Wi-Fi network.

1. Connect the iPad mobile digital device to a Wi-Fi network (not cellular).

ATTENTION: Both the NEXUS and iPad must be connected to the same local area or Wi-Fi network. The network must also be able to communicate with SKALA cloud-based servers (i.e., must have access to the internet).

2. Ensure the iPad is associated with a valid Apple ID.



Figure 2 Apple iPad with stand

3. Open the Apple App Store by scanning the QR code on the back of the NEXUS device (Figure 3).

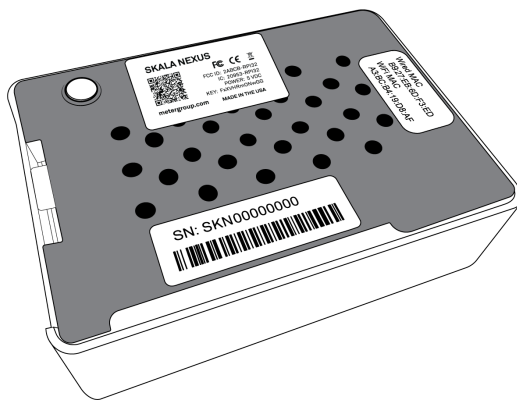

Figure 3 NEXUS back view

4. Download the SKALA Mobile by METER app (Figure 4).

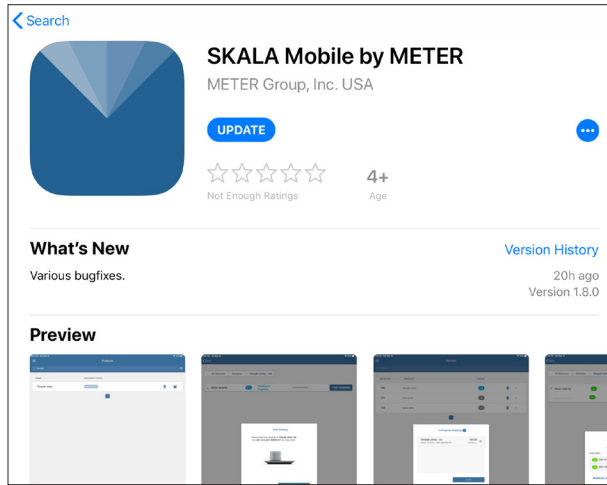

Figure 4 SKALA Mobile by METER screen

NOTE: The application can also be found by searching in the Apple App Store for SKALA Mobile by METER.

2.2.3 REGISTER NEW COMPANY SITE

Registering a new company site using the SKALA Mobile wizard bar is a one-time step. [Figure 5](#) shows the wizard bar that appears at the top of SKALA Mobile screens when the wizard is active. The wizard is only available for the first setup.



Figure 5 SKALA Mobile wizard bar

The new company SKALA account is created and the initial AQUALAB 3 is registered ([Figure 7](#) through [Figure 10](#)).

When setting up the AQUALAB 3 system for the first time, a setup wizard will take the user through the steps of registering the new company site ([Section 2.2.3](#)), connecting the first NEXUS ([Section 2.2.1](#)), and creating the first product ([Section 2.2.6](#)).

NOTE: Please consult with the information technology department for help in setting an AQUALAB 3 system up to ensure that everything is set up on the same network.

The Register device screen ([Figure 6](#)) will show up in the following situations.

- SKALA Mobile app is downloaded onto a new iPad on a new AQUALAB 3 system being set up for the first time.
- SKALA Mobile app is reloaded onto an iPad on an existing AQUALAB 3 system ([Section 2.3.1](#)).

The following steps explain how to go through the process of registering a new company site using the wizard. For subsequent additions or changes, refer to [Section](#) . Contact [Customer Support](#) with any questions or issues.

1. Adjust the iPad Display Auto-Lock settings to the desired length of time to keep the SKALA Mobile active.

If the iPad goes to sleep during initial system setup, the SKALA Mobile app will close. When the SKALA Mobil app wakes up, the screen shown in [Figure 24](#) will appear and the user will need to log back into the app.

2. Open the SKALA Mobile app on the iPad to get to the Register device dialog window ([Figure 6](#)).

Register device

Connect lab instruments and production equipment for insights in real time

SKALA is digital manufacturing for food by METER Group. Monitor your process in real time to make consistently great product for your customers. Register now to get started.

Register company

Already registered? 

Server
https://skalacontrol.com

Email

Password

Sign in

Figure 6 Register device window

3. Select the **Register company** button on the left ([Figure 6](#)).
4. Enter the company information in the upper half of the Register company window ([Figure 7](#)).

OPERATION

Back Register Company

Register a New Company

Company Information

Company Name ✓

Region ✓

Time Zone ✓

Figure 7 Company information section

5. Enter the administrator account information in the lower half of the Register company window (Figure 8).

Admin Information

Email ✓

Phone Number ✓

Username ✓

PIN ✓
PIN must be 4-10 digits

Password ✓
Password must be at least 8 characters

Confirm Password ✓

Figure 8 Admin information section

6. Enter a mobile phone number in the Connect Mobile Phone dialog window (Figure 9).
7. Select the **Send SMS** button.

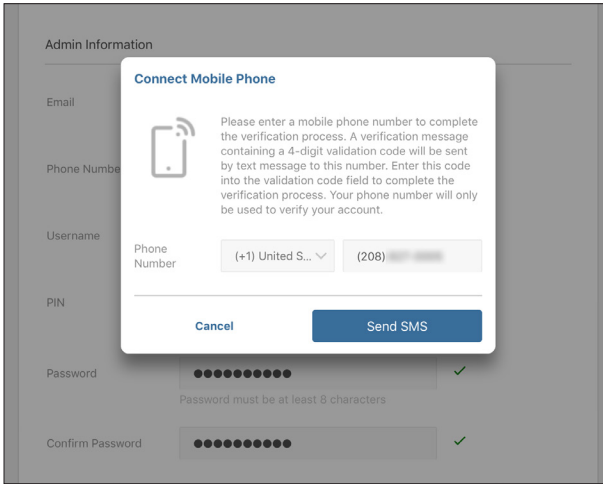

Figure 9 Connect Mobile Phone screen

A 4-digit code will be texted to the entered mobile phone number.

A Token Verification dialog window will appear (Figure 10).

8. Enter the received Token Verification code in the Enter Token field (Figure 10).
9. Select the **Verify** button (Figure 10).

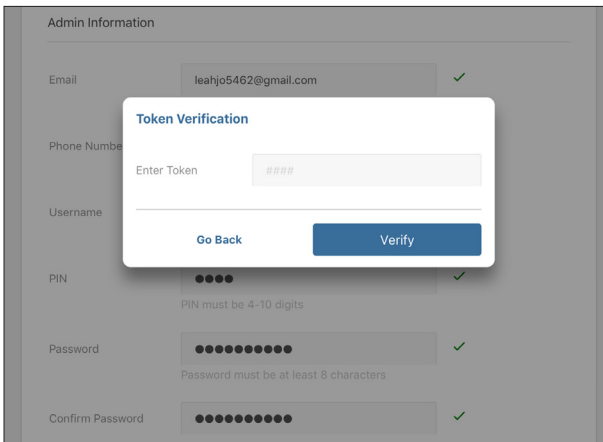

Figure 10 Token Verification screen

2.2.4 CONNECT FIRST NEXUS

The wizard automatically moves from the Register new company to Connect NEXUS. The following instructions explain how to register the first NEXUS.

1. Select **Ok** in the Register NEXUS dialog window (Figure 11).

This popup window automatically appears as part of the setup wizard function. If an error message appears, contact [Customer Support](#).

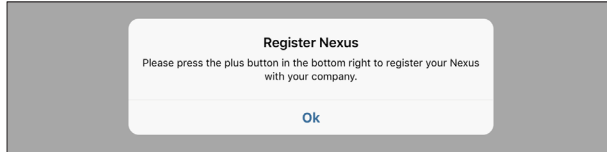

Figure 11 Register NEXUS inquiry window

2. Select the plus symbol on the screen to add a NEXUS (Figure 12).



Figure 12 Plus symbol in blue circle

3. Select **Ok** in the Register NEXUS popup window (Figure 13).

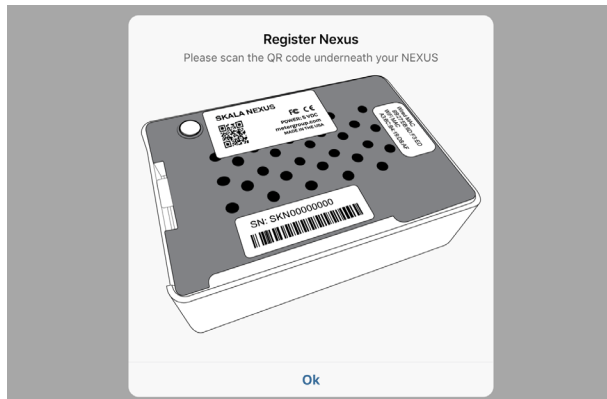

Figure 13 Register NEXUS window

The iPad camera app will open, and a dialog will appear asking for permission to access the camera (Figure 14).

4. Select **OK** in the Camera app dialog window message to give SKALA access to the iPad's camera (Figure 14).

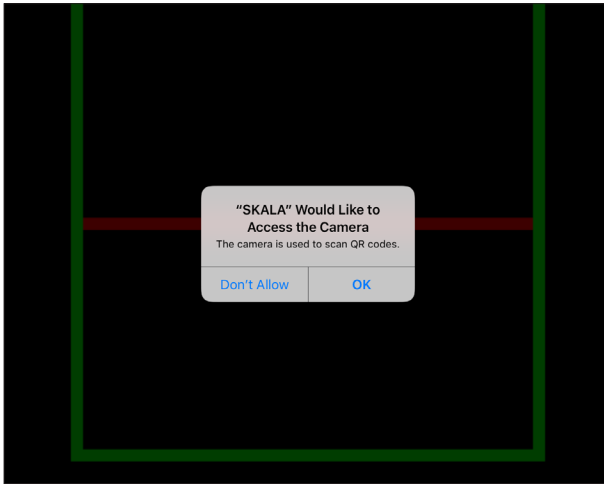

Figure 14 SKALA requests access to iPad camera

5. Turn the NEXUS over to show the labels on the bottom.
6. Place the QR code in front of the camera window and inside the green box (Figure 15).
When the camera recognizes the QR code, SKALA Mobile will automatically register the QR Code.

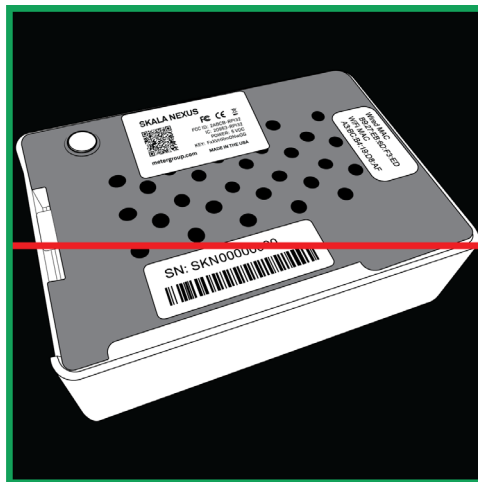

Figure 15 NEXUS in camera window

A dialog (Figure 16) will appear indicating registration success!

OPERATION

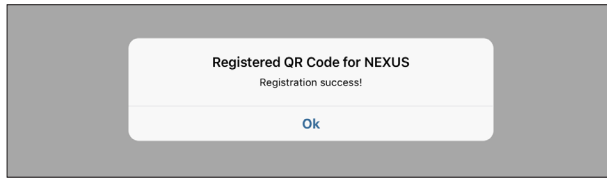

Figure 16 Registration success!

7. Select **Ok**.
8. Verify that the AQUALAB 3 system is able to locate registered NEXUSES by opening the NEXUS window from the SKALA Mobile app Main menu (Figure 17).

Any NEXUS devices should be listed here when properly registered and online.

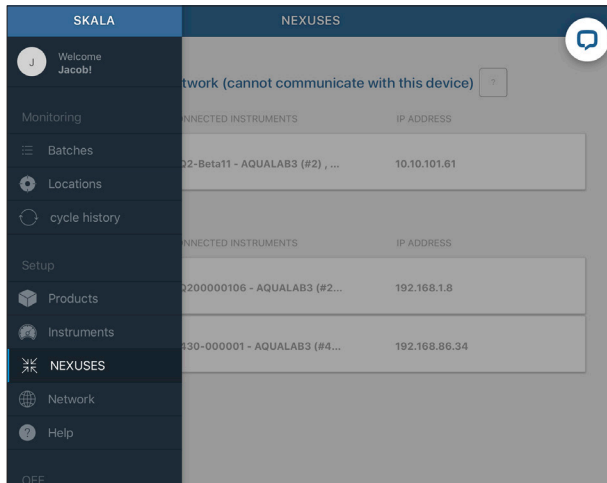

Figure 17 NEXUSES option on Main menu

The AQUALAB 3 system is now ready to add product and batch information. Please contact [Customer Support](#) if experiencing any problems registering a NEXUS.

2.2.5 ENTER SKALA MOBILE FIRST TIME

To enter SKALA Mobile the first time after registering the company, re-entering SKALA Mobile when the iPad goes to sleep, or to enter after downloading a new version of the SKALA Mobile app, please enter the following information into the Welcome to SKALA screen (Figure 18).

1. Select the dropdown menu.
2. Scroll through the list of usernames until the desired name appears.
3. Select the desired username.
4. Enter the 4-digit pin number.
5. Select the **Login** button to enter the SKALA Mobile app.

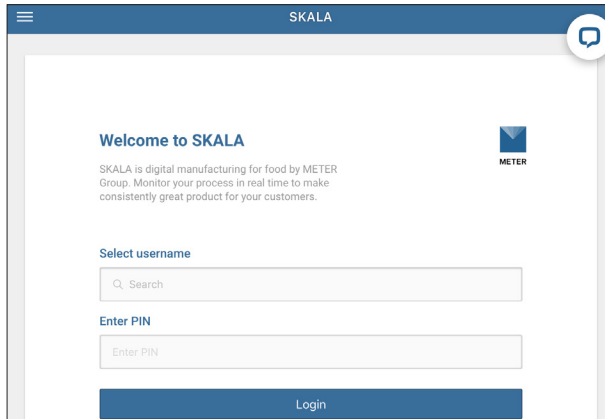

Figure 18 User login window

2.2.6 CREATE FIRST PRODUCT

Products (e.g., apple, beef jerky) must be created in the SKALA Mobile app before readings can be run or at any time from the Products page (Section 2.3.3). Products must be added prior to adding a batch (a batch refers a grouping of the product given a batch number to separate it from other batches of the same product).

The first product being added will only be available for use with the water activity reading feature as it is in the freemium version of SKALA. Water activity tests are the only tests available through the freemium version. Additional tests and features can be accessed with a monthly subscription to a premium plan. To learn more about SKALA Control subscription plans, go to metergroup.com/skala-upgrade or contact [Customer Support](#).

To create the first product, use the following steps via the SKALA Mobile app wizard.

1. Select **Ok** to begin the process of adding the first new product (Figure 19).

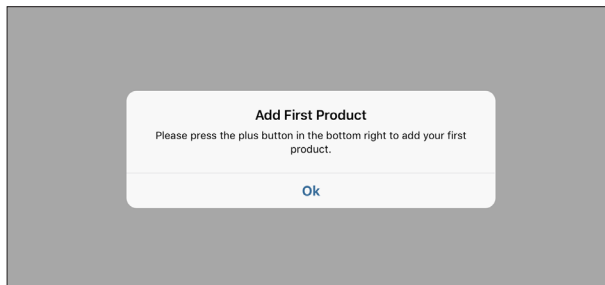

Figure 19 Add first product prompt

2. Select the plus symbol on the Products screen to add a product (Figure 20).

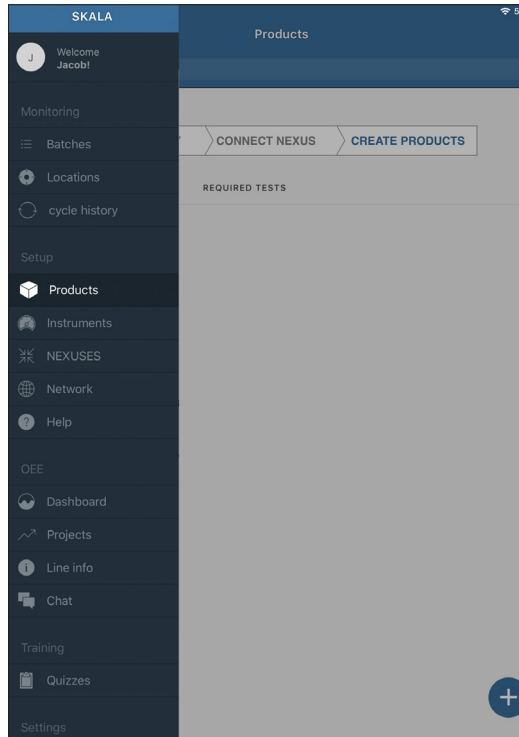

Figure 20 Plus symbol in blue circle

3. Enter the product name in the Name field (Figure 21).
4. Select Water activity from the Select test dropdown menu (Figure 21).
5. Set minimum and maximum reading values (Figure 21).

NOTE: The minimum and maximum values for a water activity reading should be integers to represent a_w values.

There is no need to do anything in the Moisture Content Model section for water activity readings.

6. Select the **Add product** button when all required information is entered (Figure 21).

NOTE: Water activity readings are the only readings available in the freemium version. Additional readings can be accessed when subscribed to a premium plan. Learn more about SKALA subscription plans at [metergroup.com/skala-upgrade](https://www.metergroup.com/skala-upgrade) or contact [Customer Support](#).

profile.skalacontrol.com/#/products'; and 'Moisture Content Model' with a dropdown menu for 'Select moisture content model'. At the bottom, there are two buttons: 'Cancel' and 'Add product'."/>

Add a new product [X]

Product information

Name

Add required test

Select test [trash icon]

Min value

Max value

Add required test +

Additional tests can be added on SKALA Control at: profile.skalacontrol.com/#/products

Moisture Content Model

Cancel **Add product**

Figure 21 Add a new product window

Figure 22 will appear once a Product has been added.

OPERATION

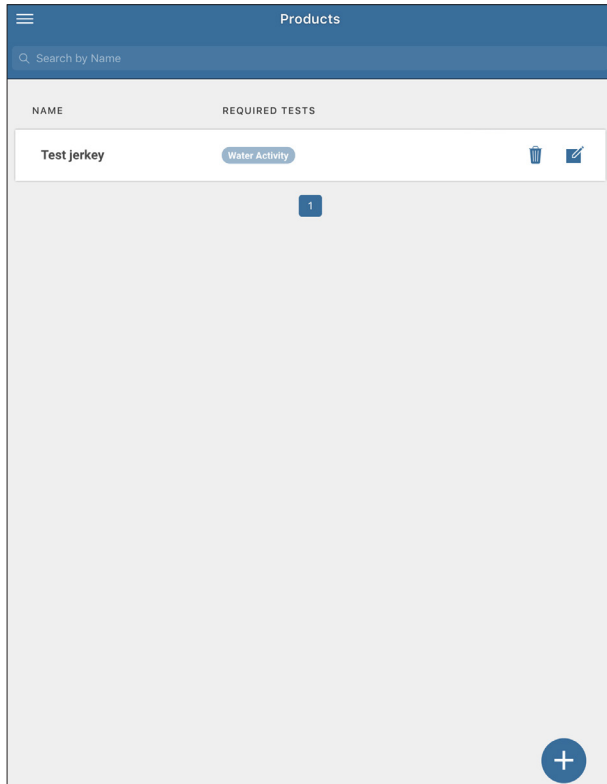

Figure 22 Products window

Please contact [Customer Support](#) if experiencing problems.

2.3 ENTER EXISTING COMPANY SITE

This section provide instructions to sign into an existing company account after using the wizard for the first set up. How to handle the following will be explained.

- Add additional iPads
- Add additional NEXUSES
- Add new water activity products
- Verify NEXUS is visible on network
- Select market groups (subscription required)
- Add new total moisture products (subscription required)
- Remove products

2.3.1 ADD ADDITIONAL IPADS TO EXISTING SYSTEM

If the SKALA Mobile app has been downloaded onto a new iPad in an existing system, follow the instructions below.

NOTE: If this is to set up a new system for the first time, please go to [Section 2.2.3](#).

1. Open SKALA Mobile app on the iPad.
2. Select the desired server to log into from the dropdown menu options in the Register device window ([Figure 23](#)).
3. Enter the company email address and password in the fields on the right side of the window.

Figure 23 Sign in to existing company

4. Select the **Sign In** button to go to the Welcome to SKALA window ([Figure 24](#)).

Figure 24 User log in window

2.3.2 ADD ADDITIONAL NEXUSES

If another NEXUS or additional NEXUSES need to be set up, please do the following:

1. Open the SKALA Mobile app menu using the menu icon located in the upper left corner of the screen.

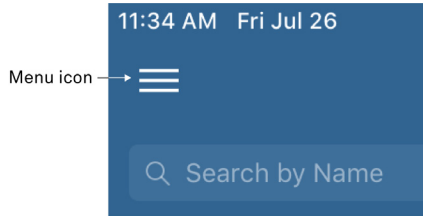

Figure 25 Menu icon

2. Select NEXUS in the menu under Setup to open a window with a list of currently registered NEXUSES (Figure 26).

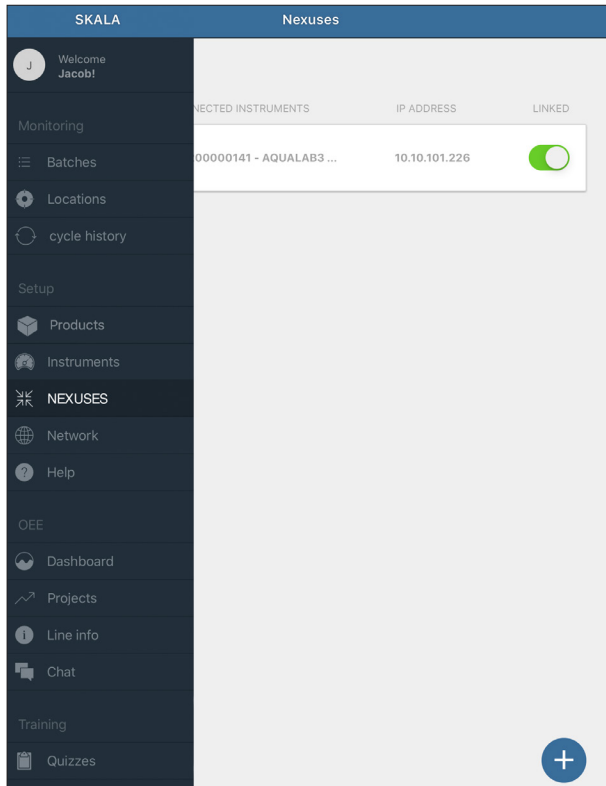

Figure 26 NEXUSES window

3. Select the plus symbol on the NEXUES screen to register another NEXUS (Figure 26).
4. Select **Ok** in the Register NEXUS popup window (Figure 27).

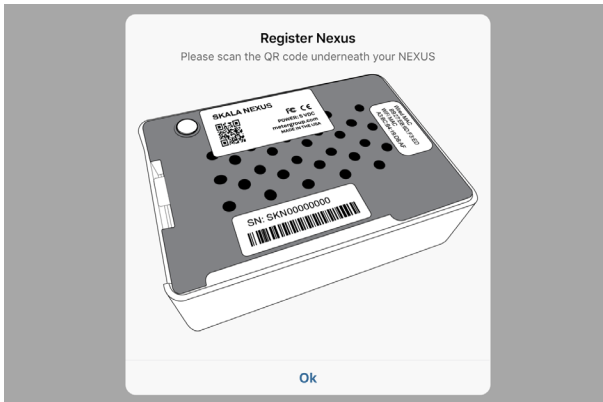

Figure 27 Register NEXUS window

The iPad camera app will open, and a dialog will appear asking for permission to access the camera (Figure 28).

5. Select **OK** in the Camera app dialog window message to give SKALA access to the iPad's camera (Figure 28).



Figure 28 SKALA requests access to iPad camera

6. Turn the NEXUS over to show the labels on the bottom.
7. Place the QR code in front of the camera window and inside the green box (Figure 29).
When the camera recognizes the QR code, SKALA Mobile will automatically register the QR Code.

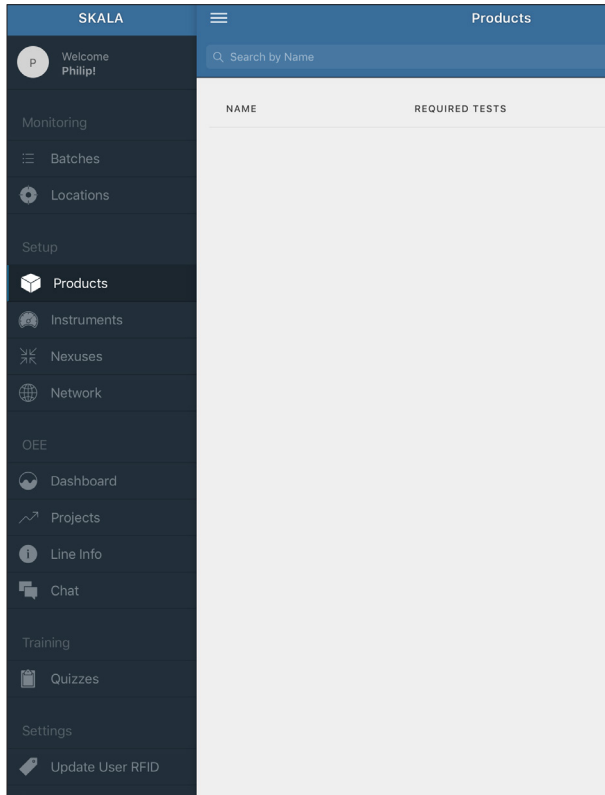

Figure 31 Products option in Main menu

3. Select the plus symbol on the Products screen to add a new Product (Figure 31).
4. Enter the product name in the Name field (Figure 32).

Figure 32 Add a new product window

5. Select Water activity from the Select test dropdown menu (Figure 32).
6. Set minimum and maximum reading values (Figure 32).

NOTE: The minimum and maximum values for a water activity reading should be integers to represent a_w values.

There is no need to do anything in the Moisture Content Model section for water activity readings.

7. Select the **Add product** button when all required information is entered (Figure 32).

NOTE: Water activity readings are the only readings available in the freemium version. Additional readings can be accessed when subscribed to a premium plan. Learn more about SKALA subscription plans at metergroup.com/skala-upgrade or contact [Customer Support](#).

Figure 33 will appear once a Product has been added .

AQUALAB 3

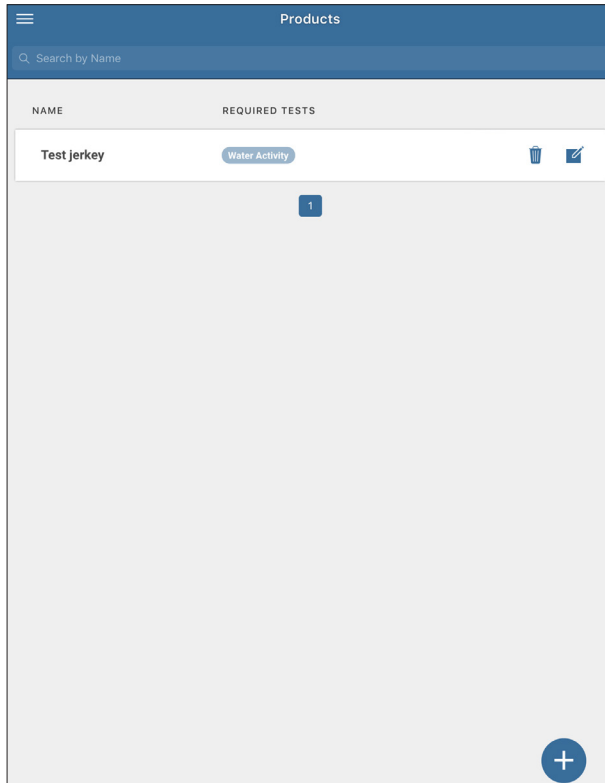

Figure 33 Products window

Please contact [Customer Support](#) if experiencing problems.

If products need to be removed from SKALA Mobile, please follow the steps below:

1. Open the SKALA Mobile app menu by selecting the menu icon located in the upper left corner of the screen.

OPERATION

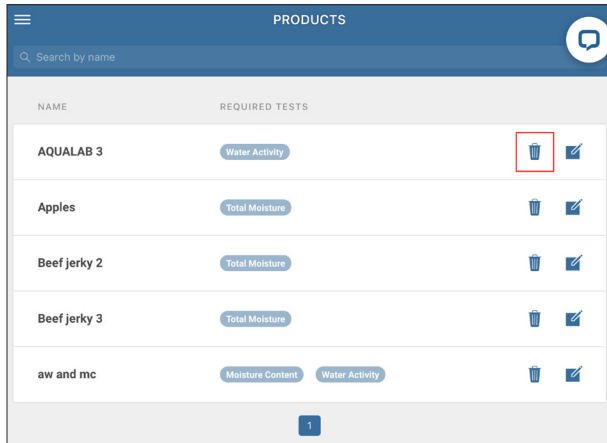

Figure 34 Products list

2. Select Products under Setup.
3. Press on the garbage can icon to remove the product (Figure 34).
The Remove Product dialog window like the one below will appear (Figure 35).
4. Select the **Remove** button.

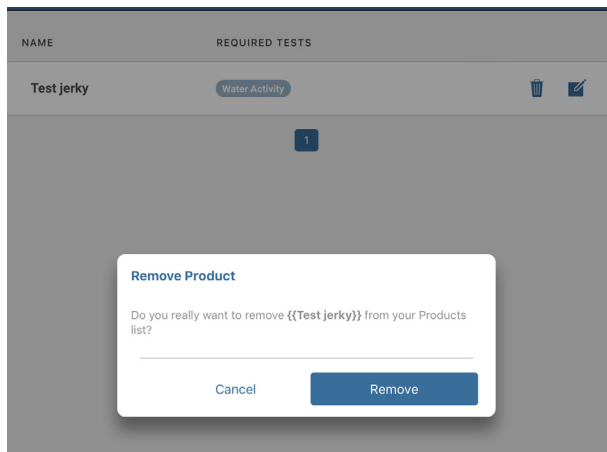

Figure 35 Remove Product dialog

Please contact [Customer Support](#) if experiencing any problems adding or removing products.

2.3.4 SELECT MARKET GROUPS (SUBSCRIPTION REQUIRED)

Selecting specific market groups (maximum of two are allowed) reduces the moisture content models options list to include only those in the market groups selected. The option to select market groups is only available with one of the many subscriptions.

The first time after the subscription is activated, SKALA Mobile will require the user to select a maximum of two market groups.

These instructions explain how to select market groups.

1. Open the SKALA Mobile app after activating a subscription.
2. Log into the company site (Figure 23).
3. Select Products from the main menu to open the Products window (Figure 40).
4. Start the process to add a new product (Section 2.3.3).

The SKALA Mobile app will automatically open the Batches page with a message prompt to set market groups (Figure 36).

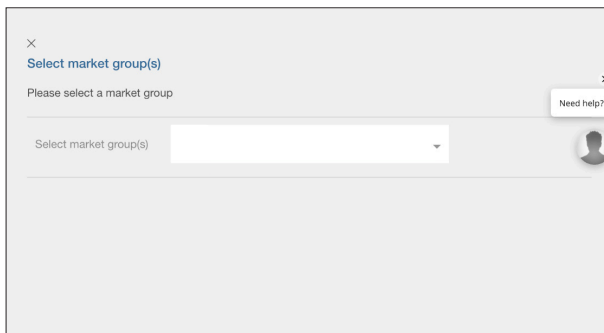

Figure 36 Market group setup message

5. Place cursor in Select market group(s) field to open a market group popup window (Figure 37).

A maximum of two market groups are allowed. An error message will appear if a third selection is attempted.

6. Select the **Confirm** button when selections are completed (Figure 37).

OPERATION

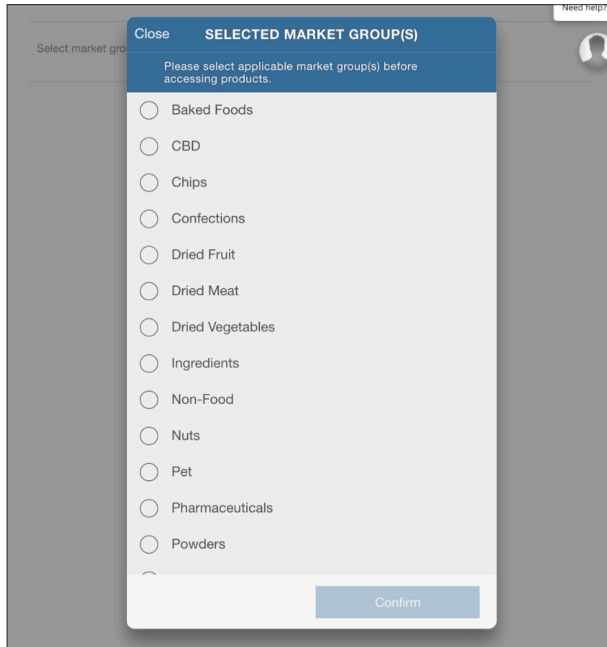

Figure 37 Choose market groups

7. Review the market groups listed in the Select market group(s) field (Figure 38).
8. Select the **Submit** button (Figure 38).

Make sure the listed market groups are correct. The only way to change market groups once submitted is to contact [Customer Support](#).

×

Select market group(s)

Are you sure about your market group selection? Once this has been set, this can only be changed by contacting support at 1-509-332-5601 or support.skala@metergroup.com.

Need help? X

Select market group(s) Dried Meat
Dried Fruit

Cancel Submit

Figure 38 Submit chosen market groups

9. Edit any products set up before defining market groups and update the Moisture Content Model selection (Figure 38).

After the market groups are submitted, the list of models in the Moisture Content Model in the Product screen will look like (Figure 39).

OPERATION

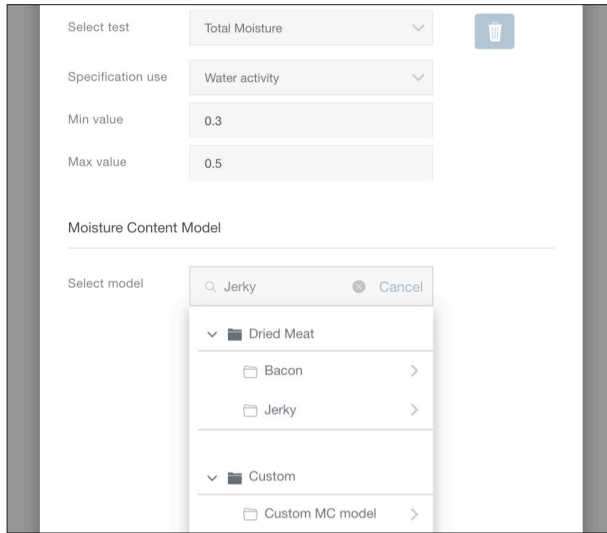

Figure 39 Market groups in Product setup screen

2.3.5 ADD FIRST TOTAL MOISTURE PRODUCT (SUBSCRIPTION REQUIRED)

To add a new product for a total moisture reading, a monthly subscription to SKALA Control is required. To find out more about SKALA Control subscription plans, go to metergroup.com/skala-upgrade or contact [Customer Support](#).

Please use the following steps to add a new product for a total moisture reading using a water activity specification.

1. Open the SKALA Mobile app menu by selecting the menu icon located in the upper left corner of the screen.
2. Select Products under Setup ([Figure 40](#)).

This will open the Products window.

NOTE: Tap on the main screen (white or gray area) area to the right of the menu to close the menu.

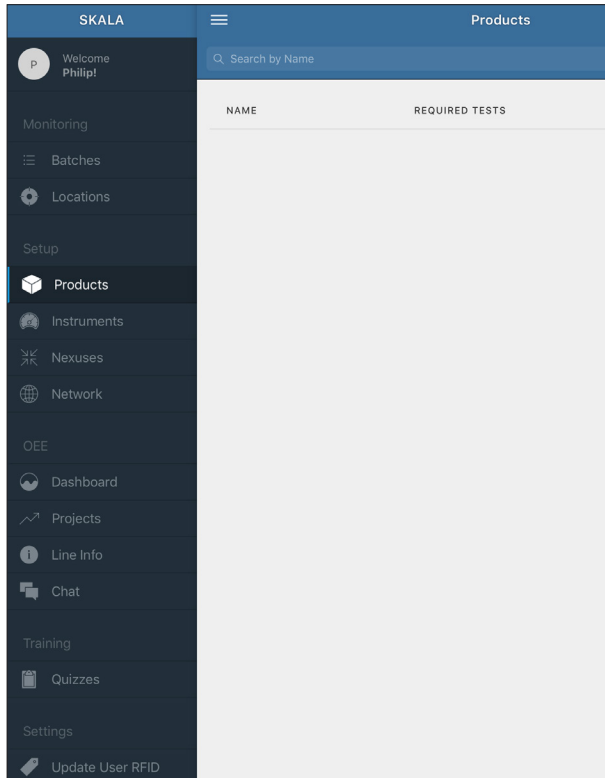

Figure 40 Products option in Main menu

3. Select the plus symbol on the Products screen to add a product.
4. Enter the product Name (Figure 41).
5. Select Total Moisture from the Select test dropdown menu (Figure 41).
6. Select Water activity or Total moisture from the Specification use dropdown menu (Figure 41).
7. Set minimum and maximum reading values based on the specification chosen in previous step (Figure 41).

NOTE: Total moisture reading values using water activity specifications should be indicated by integers to represent a_w values and moisture content specifications should use numbers representing a percentage.
8. Select the Moisture Content Model from the dropdown menu at the bottom of the window (Figure 41).
9. Select the **Add (Update) product** button (Figure 41) when all required information is entered.

NOTE: Water activity tests are always available. Additional tests can be added when subscribed to a premium plan. Learn more about SKALA subscription plans at metergroup.com/skala-upgrade or contact **Customer Support**.

OPERATION

PRODUCTS

Search by name

Add a new product

Product information

Name: Apples

Add required test

Select test: Total Moisture

Specification use: Water activity

Min value: 0.3

Max value: 0.7

Moisture Content Model

Select model: Apple, Dried

Additional tests can be added on SKALA Control at: skalacontrol.com/#/products

Cancel Add product

Total Moisture—Water Activity (a_w)

PRODUCTS

Search by name

Edit an existing Product

Product information

Name: Apples

Add required test

Select test: Total Moisture

Specification use: Moisture Content

Min value: 5

Max value: 10

Moisture Content Model

Select model: Apple, Dried

Additional tests can be added on SKALA Control at: skalacontrol.com/#/products

Cancel Update Product

Total Moisture—Moisture Content (%)

Figure 41 Add a new/edit existing product

The Product screen will appear with the newly added/updated Product listed (Figure 43).

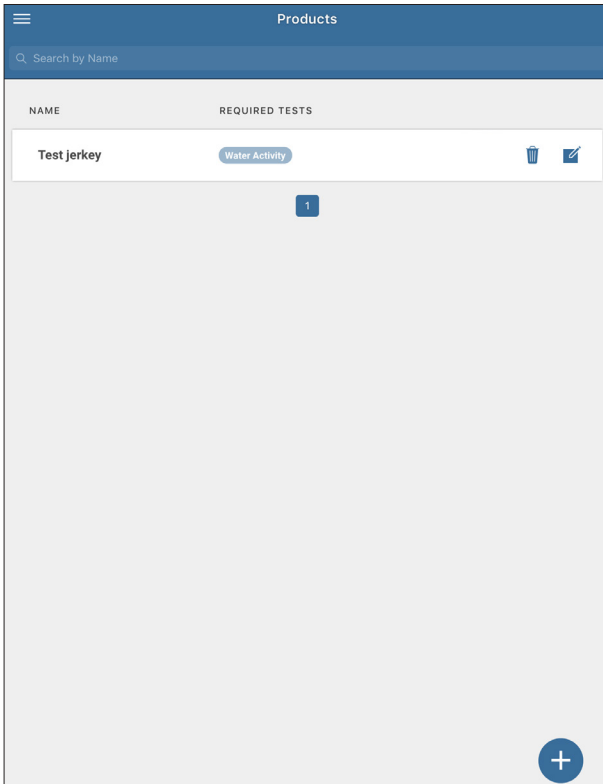

Figure 42 Products window

Please contact [Customer Support](#) if experiencing problems.

If products need to be removed from SKALA Mobile, please follow the steps below:

1. Open the SKALA Mobile app menu by selecting the menu icon located in the upper left corner of the screen.

OPERATION

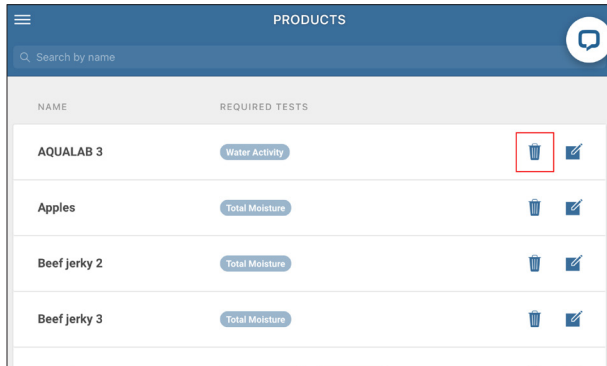

Figure 43 Products list

2. Select Products under Setup.
3. Press on the garbage can icon to remove the product (Figure 43).
The Remove Product dialog window like the one below will appear (Figure 44).
4. Select the **Remove** button.

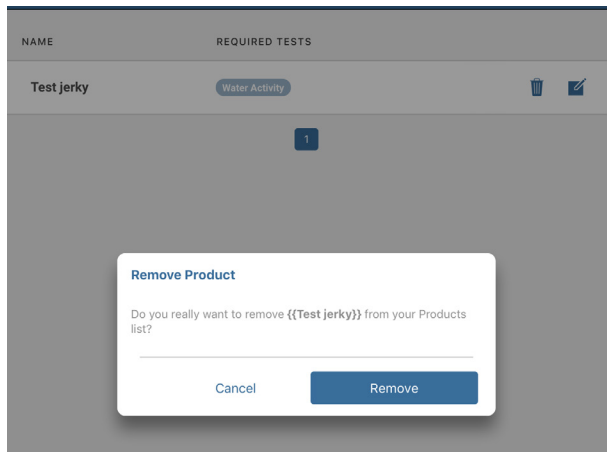

Figure 44 Remove Product dialog

Please contact [Customer Support](#) if experiencing any problems adding or removing products.

2.4 ADD A BATCH

The following steps explain how to add a batch. Adding a batch leads to setting up a sample, which is the first step in preparing for a reading (Section 2.5).

1. Open the SKALA Mobile app menu by selecting the menu icon located in the upper left corner of the screen.
2. Select Batches listed under Monitoring at the top of the Main menu.

NOTE: Tap on the main screen (white or gray area) area right of the menu to close the menu.

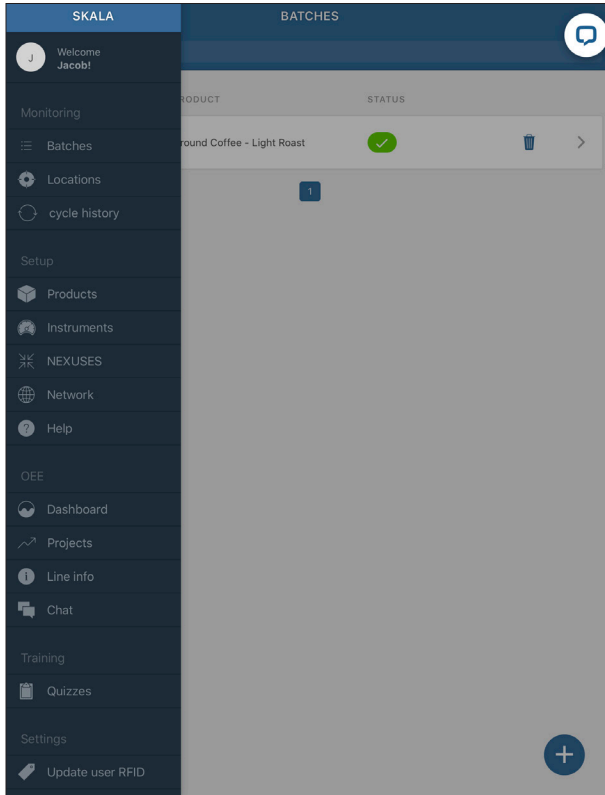
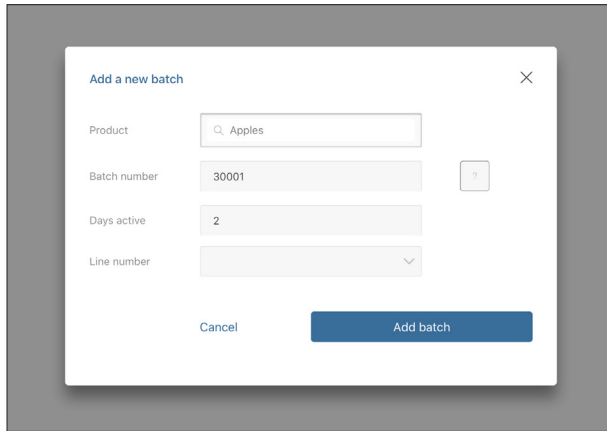

Figure 45 Batches window

3. Select the plus symbol on the Batches screen to add a Batch (Figure 45). This will open the Batches screen (Figure 46).

OPERATION



The image shows a 'Add a new batch' popup window. The window has a title bar with the text 'Add a new batch' and a close button (X). Below the title bar, there are four input fields: 'Product' with a search icon and the text 'Apples', 'Batch number' with the text '30001' and a help icon, 'Days active' with the text '2', and 'Line number' with a dropdown arrow. At the bottom, there are two buttons: 'Cancel' and 'Add batch'.

Figure 46 Add a new batch popup window

4. Select the product from the dropdown list (Figure 46).
5. Enter a batch number (Figure 46).
For information on autogenerated batch numbers, please contact [Customer Support](#).
6. Enter the number of days visible in SKALA Mobile in the Days Active field.
After that, the batch can be accessed in SKALA Control (Figure 46).
7. Enter the line number that identifies specific customer selected process line in the Line Number field (Figure 46).
This step is optional.
8. Select the **Add batch** button to save the new batch information (Figure 46).
The Batches window will open showing a list of batches (Figure 47).

AQUALAB 3

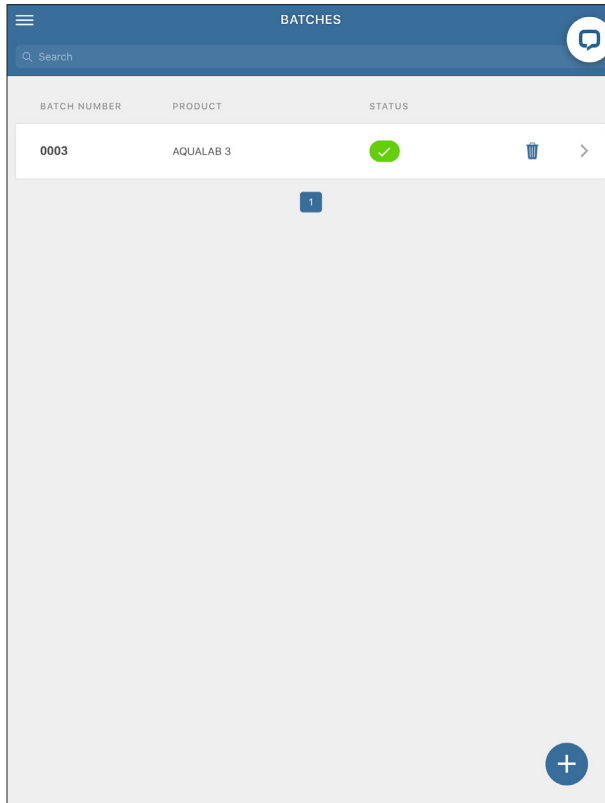

Figure 47 Example Batches page

2.5 TAKE A READING

The SKALA Mobile app handles the entire interface for setting up and taking readings with the AQUALAB 3. Water activity readings can be taken with an AQUALAB 3 system with either freemium or subscription access. Access to additional features can be added when a subscription to a monthly plan is activated. Learn more about SKALA subscription plans at metergroup.com/skala-upgrade or contact [Customer Support](#).

Before testing a sample, ensure that the AQUALAB 3 has warmed up for at least 30 min and that the sample chamber and cover are clean and dry.

NOTE: SKALA Mobile will prompt the user to verify the calibration of the AQUALAB 3 according to the frequency established by the administrator in SKALA Control ([Section 4.1](#)).

2.5.1 WATER ACTIVITY READING

This section contains information on taking water activity readings.

1. Open the SKALA Mobile app menu by selecting the menu icon located in the upper left corner of the screen.
2. Select Batches listed under Monitoring at the top of the menu.
This will open the Batches screen with a list of available batches.
3. Select the right-pointing arrow at the far right of the batch to be tested (Figure 47).
4. Select the plus symbol in the blue circle in the lower left corner of the Batches screen to open the Add sample popup window (Figure 48).
5. Select the **Add sample** button (Figure 48).

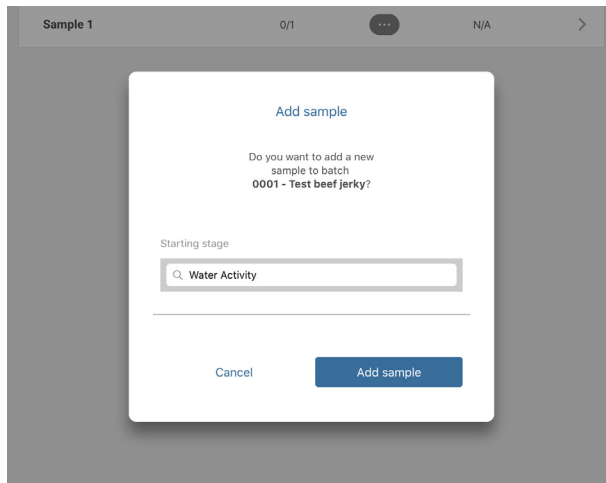

Figure 48 Add sample popup screen

6. Select the **Take reading** button to start the reading process (Figure 49).

NOTE: Products (Section 2.2.6) and batches (Section 2.4) must be added to the SKALA Mobile app before a reading can be taken.

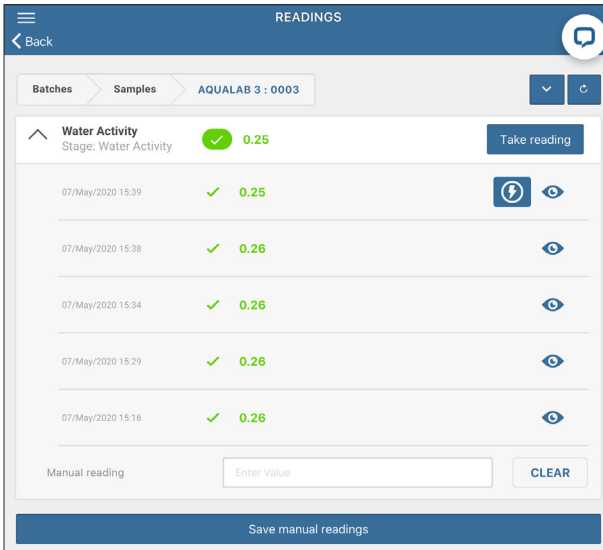

Figure 49 Take reading on Readings window

7. Select Take reading to the right of the device name shown in the Take reading popup window (Figure 50).

NOTE: A list of all available instruments in the network will appear in the Readings screen. If no instrument is listed, please see Troubleshooting.

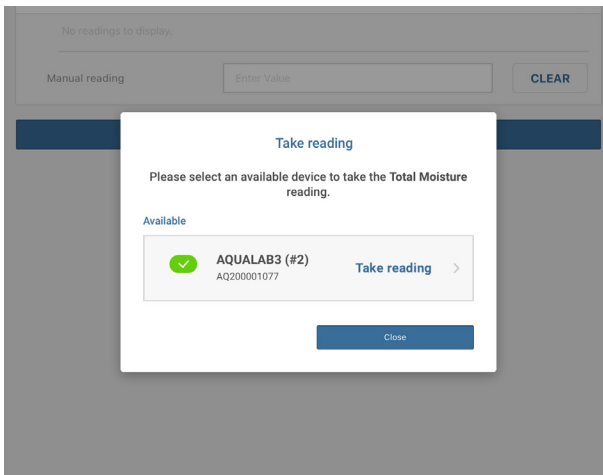

Figure 50 Take reading popup window

On the selected AQUALAB 3 device (Figure 51), the indicator light will turn blue and spin counterclockwise, indicating that the system is ready to collect a reading.

OPERATION

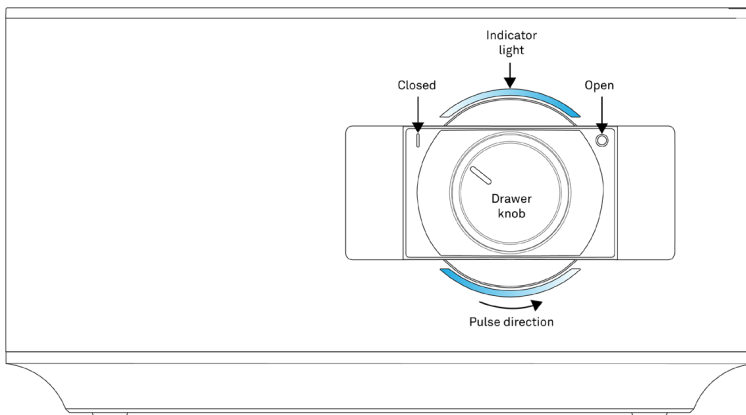

Figure 51 Front-panel drawer knob

8. Prepare the sample using clean sampling practices to ensure accurate and repeatable readings.
 - a. Wash hands thoroughly or put gloves on prior to using the instrument.
[Section 4.2](#) for detailed cleaning methods.
 - b. Fill the sample cup ([Figure 52](#)) enough to cover the bottom but no more than half full. Clean sample cup bottom, sides, and rim thoroughly with KIMWIPES® strips.



Figure 52 Sample Cup

Keep samples in sealed packaging or in a sample cup with a sample cup lid when a sample is not actively being read. Otherwise, the sample water activity will slowly equilibrate with the humidity in the ambient air.

NOTE: If the sample will be sitting for more than 2 h before being read, seal the sample cup edges with a piece of parafilm or a similar material.

9. Insert the sample cup into the AQUALAB 3 sample chamber ([Figure 53](#)):
 - a. Pull out sample drawer.
 - b. Lift the sample cover.
 - c. Place the sample cup (without the sample cup lid) into the sample chamber.
 - d. Lower the sample cover down over the sample cup.
 - e. Push the drawer closed.

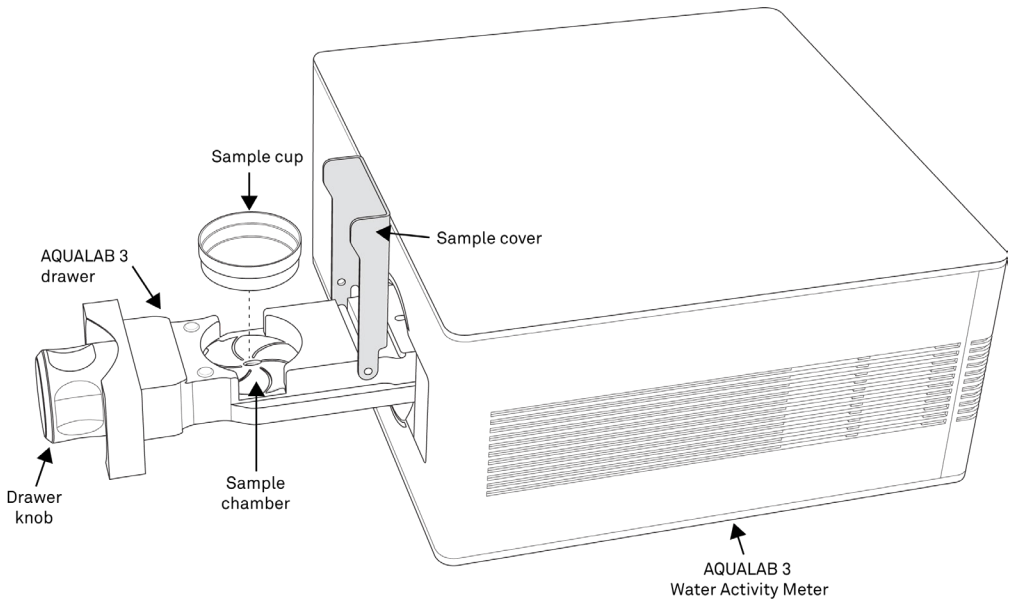

Figure 53 AQUALAB 3 Drawer Pulled Out

10. Choose method (a) or (b) described below to start the reading.

- a. Turn the drawer knob counterclockwise (left) to the Closed position to begin the reading (Figure 54).

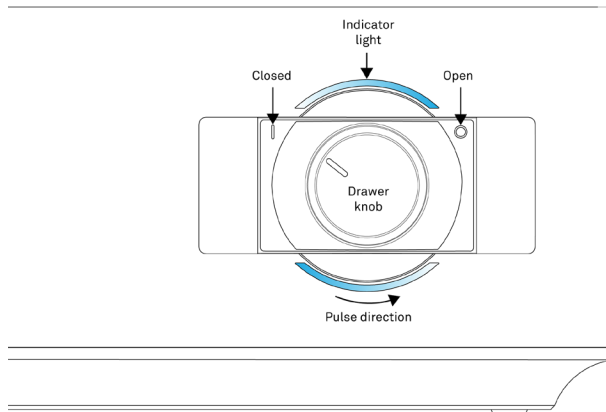

Figure 54 Front-panel drawer knob

This will automatically start the test.

The AQUALAB 3 will start the reading and a slow pulsing blue light will show on the front panel while the reading is in progress. A Reading in Progress message will appear on the app screen.

OPERATION

- b. Select the **Start** button on the Take Reading dialog box to start the reading if the sample is already loaded and the drawer knob is turned to the left (Figure 55).

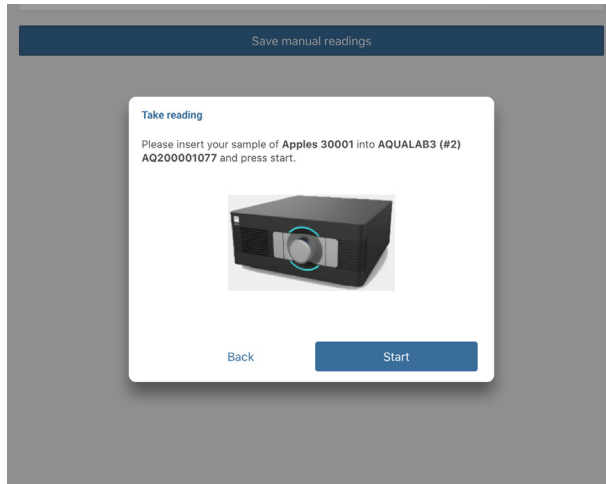

Figure 55 Take Reading popup

11. Select the **In-Progress Readings** button at the bottom of the Readings screen to see the In-Progress Readings dialog window with the reading status (Figure 56).

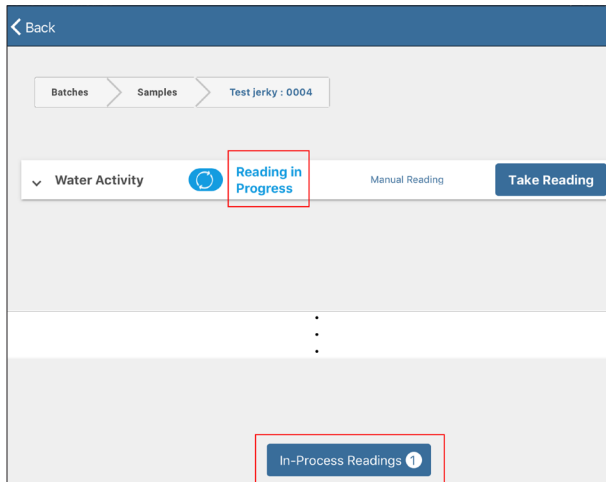

Figure 56 Reading in progress indicator

The In Progress Readings popup window will appear (Figure 57).

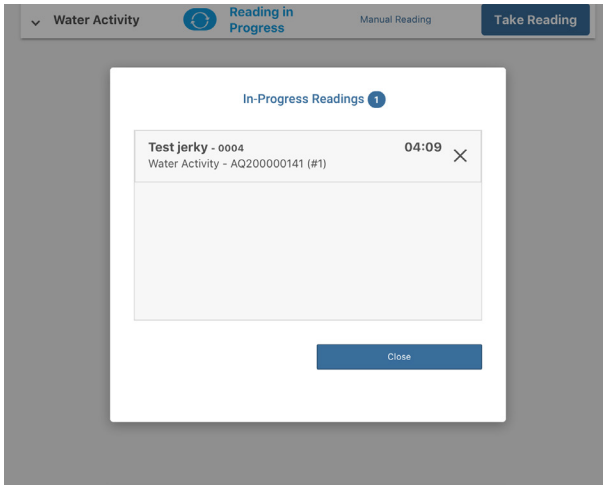

Figure 57 In Progress Reading popup window

12. Select the **Close** button to close the In-Progress dialog window and return to the readings window (Figure 57).
13. When the reading is finished, a dialog box will appear in SKALA Mobile with test details (Table 1).

The AQUALAB 3 indicator light (Figure 58) will turn either a solid green, yellow, or red, indicating the knob should be turned towards the **Open** position. The color signal corresponds to the reading received and should match the result in the SKALA Mobile dialog.

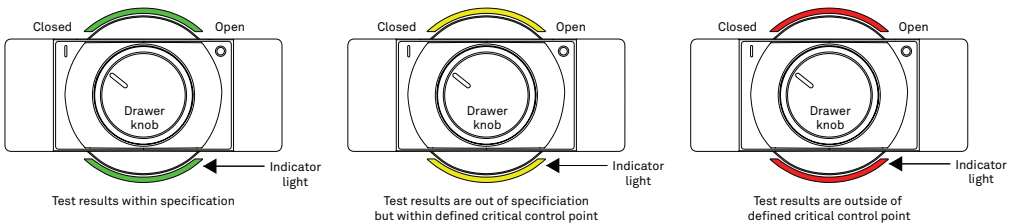



Figure 58 Front-panel indicator light

Table 1 shows the water activity reading indicators.

Table 1 Completed Water Activity Reading Indicator

You've just received a Reading for Review ×

Within Spec

Reading Type	Water Activity
Value	0.271 a _w
Batch	0004
Sample	1
Product	Test jerky
Date	29 Jul 2019 - 10:52
Instrument	AQ200000141 (#1)

Solid green indicates the reading is within defined operational limits.

You've just received a Reading for Review ×

Outside of Operating Limits
Reading must be between 0.1 and 0.9

Reading Type	Water Activity
Value	0.998 a _w
Batch	11-02Aug191635
Sample	1
Product	TEST002AW
Date	02 Aug 2019 - 16:40
Instrument	AQ200000134 (#7)

Solid yellow indicates the reading is outside of defined operational limits but within defined fail limits.

You've just received a Reading for Review ×

Outside of Fail Limits
Reading must be between 0.5 and 0.6

Reading Type	Water Activity
Value	1.002 a _w
Batch	11-02Aug191641
Sample	1
Product	TT001
Date	02 Aug 2019 - 16:51
Instrument	AQ200000134 (#7)

Solid red indicates that the reading is outside of defined fail limits.

See [Troubleshooting](#) for information on what to do if the indicator light is red.

A flashing red indicator light means there is an error associated with the AQUALAB 3. SKALA Mobile should indicate what the error is and how to fix the error. If the error is not actionable by the user, a message will be to contact [Customer Support](#).

- Turn the drawer knob clockwise and open the drawer (Figure 54).

The reading data will automatically be saved in SKALA Control with the associated product batch and information about the instrument used to test the sample. Figure 59 shows a list of previous batch readings displayed in SKALA Mobile on the iPad.

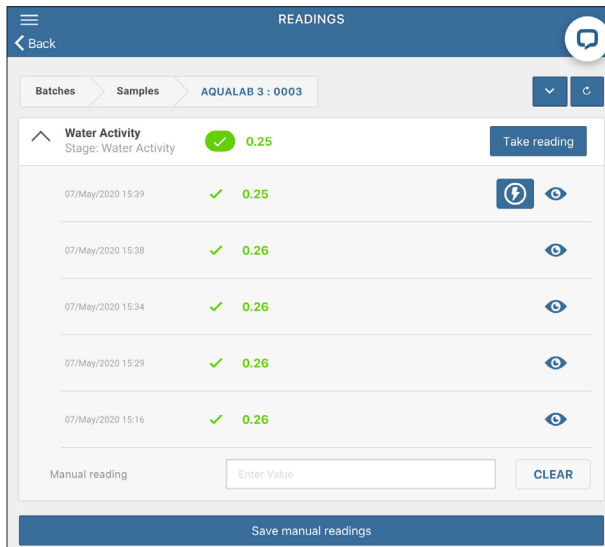

Figure 59 List of completed water activity readings

The AQUALAB 3 reports the reading when equilibrium is reached; for many products, equilibrium will occur in 5 min or less. However, some types of products may take longer, such as products with

- a moisture barrier (e.g., whole seeds and nuts),
- a high fat content (e.g., peanut butter),
- extremely low water activity, or
- multiple components (e.g., cakes with filling, cheese and crackers, cereal with fruit).

Contact [Customer Support](#) to help determine if the product requires longer read times and if any actions may shorten the read time.

2.5.2 TOTAL MOISTURE READING

This section contains information about taking total moisture readings which require a subscription. Learn more about SKALA subscription plans at metergroup.com/skala-upgrade or contact [Customer Support](#).

Traditionally, companies are used to just getting half of the moisture picture by only measuring moisture content. Measuring and knowing just moisture content gives yield and some vague quality data. By also knowing moisture energy (water activity) you will get high-resolution quality and safety information of the product, like how it relates to lipid oxidation, browning, caking, and clumping. The difference between crisp and stale can be pinpointed by knowing the water activity and not moisture content.

OPERATION

With the invention of AQUALAB 3, food manufactures can get both moisture content and water activity in 1 min, which gives them the total moisture picture, product yield, quality, and safety. This allows food manufactures to decrease rework and waste while increasing product consistency and making a significant business impact.

Follow the instructions below to take a total moisture reading.

NOTE: Market Groups must be set up ([Section 2.3.4](#)) before the first Total Moisture reading is taken. The following instructions assume a subscription is active and Market Groups are set up.

1. Open the SKALA Mobile app menu by selecting the menu icon located in the upper left corner of the screen.
2. Select Batches listed under Monitoring at the top of the menu.
This will open the Batches screen with a list of available batches.
3. Select the right-pointing arrow at the far right of the batch to be tested ([Figure 47](#)).
4. Select the plus symbol in the blue circle in the lower left corner of the Batches screen to open the Add sample popup window ([Figure 60](#)).
5. Select the **Add sample** button ([Figure 60](#)).

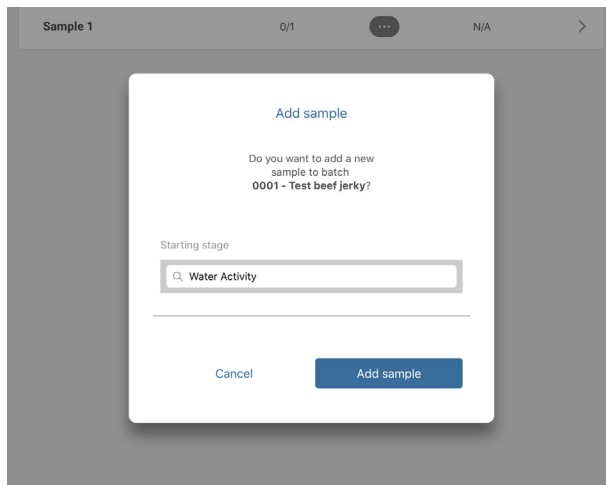

Figure 60 Add sample popup screen

6. Select the **Take reading** button to start the reading process ([Figure 61](#)).

NOTE: Products ([Section 2.2.6](#)) and batches ([Section 2.4](#)) must be added to the SKALA Mobile app before a reading can be taken.

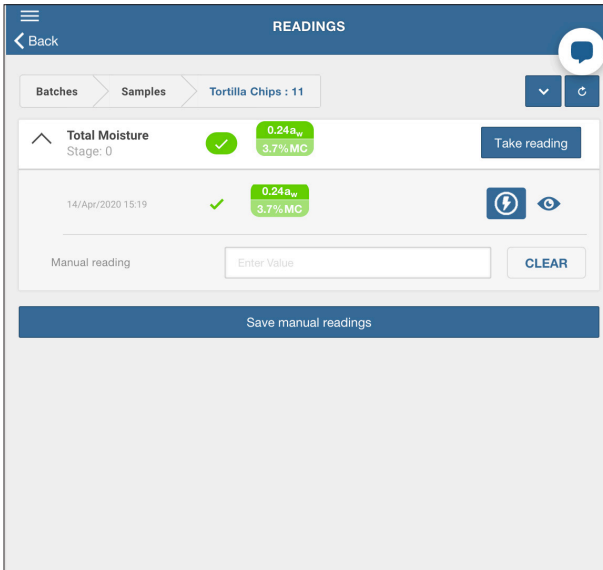

Figure 61 Take reading on Readings window

7. Select Take reading to the right of the device name shown in the Take reading popup window (Figure 62).

NOTE: If no instrument is listed, please see [Troubleshooting](#).

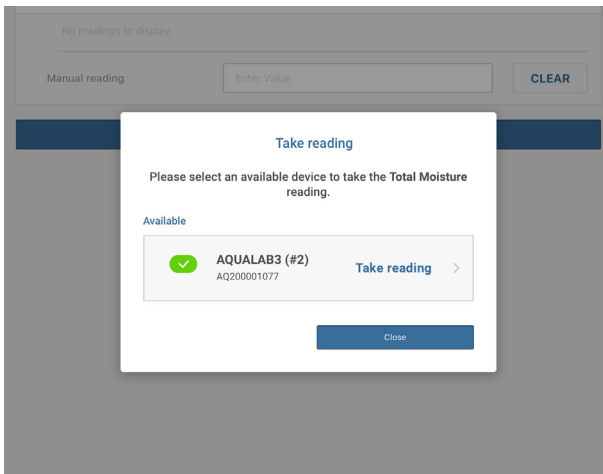

Figure 62 Take reading popup window

On the selected AQUALAB 3 device (Figure 63), the indicator light will turn blue and spin counterclockwise, indicating that the system is ready to collect a reading.

OPERATION

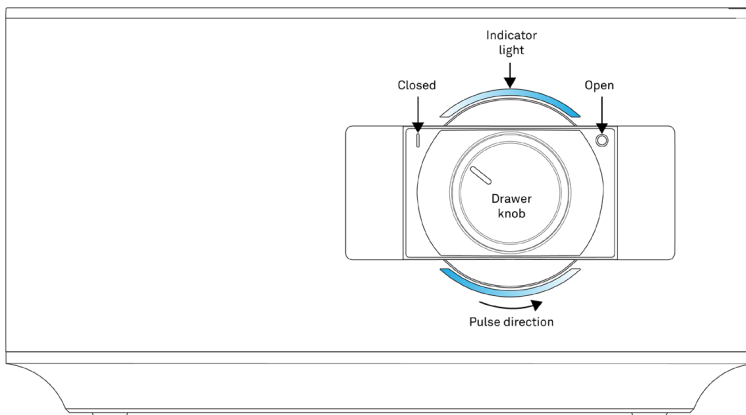

Figure 63 Front-panel drawer knob

8. Prepare the sample using clean sampling practices to ensure accurate and repeatable readings.
 - a. Wash hands thoroughly or put gloves on prior to using the instrument.
[Section 4.2](#) for detailed cleaning methods.
 - b. Fill the sample cup ([Figure 64](#)) enough to cover the bottom but no more than half full. Clean sample cup bottom, sides, and rim thoroughly with KIMWIPES® strips.



Figure 64 Sample Cup

Keep samples in sealed packaging or in a sample cup with a sample cup lid when a sample is not actively being read. Otherwise, the sample water activity will slowly equilibrate with the humidity in the ambient air.

NOTE: If the sample will be sitting for more than 2 h before being read, seal the sample cup edges with a piece of parafilm or a similar material.

9. Insert the sample cup into the AQUALAB 3 sample chamber ([Figure 65](#)):
 - a. Pull out sample drawer.
 - b. Lift the sample cover.
 - c. Place the sample cup (without the sample cup lid) into the sample chamber.
 - d. Lower the sample cover down over the sample cup.
 - e. Push the drawer closed.

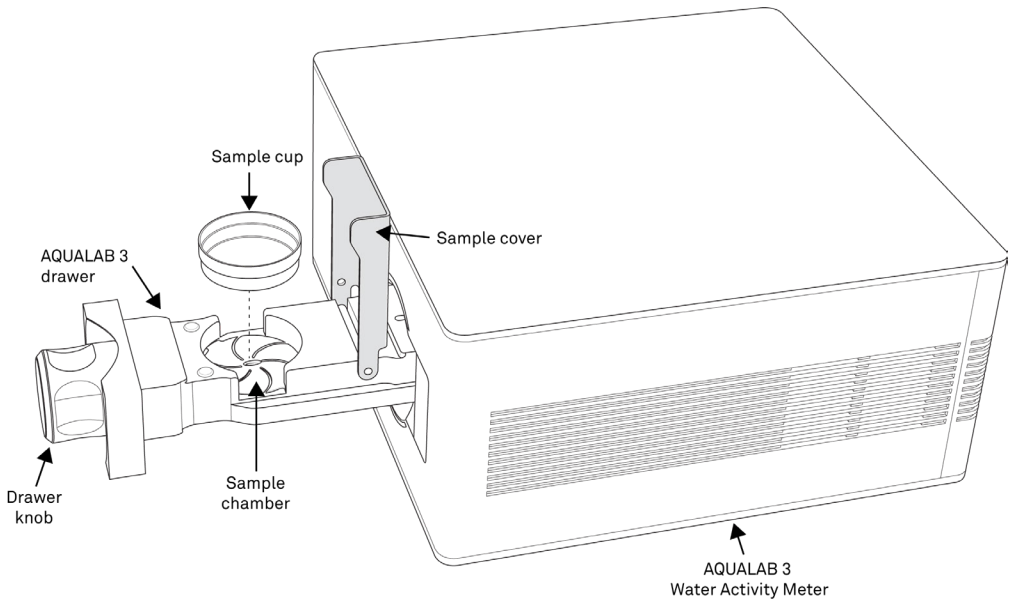

Figure 65 AQUALAB 3 Drawer Pulled Out

10. Choose method (a) or (b) described below to start the reading.

- a. Turn the drawer knob counterclockwise (left) to the Closed position to begin the reading (Figure 66).

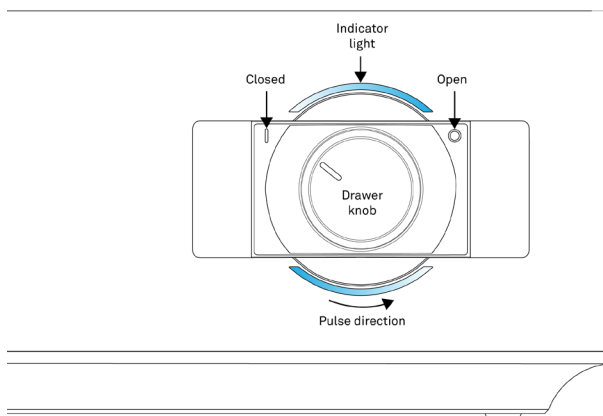

Figure 66 Front-panel drawer knob

This will automatically start the test.

The AQUALAB 3 will start the reading and a slow pulsing blue light will show on the front panel while the reading is in progress. A Reading in Progress message will appear on the app screen.

OPERATION

- b. Select the **Start** button on the Take Reading dialog box to start the reading if the sample is already loaded and the drawer knob is turned to the left (Figure 67).

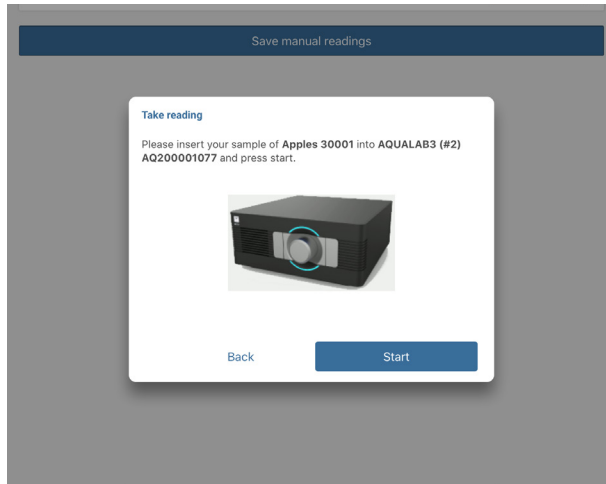

Figure 67 Take Reading popup

11. Select the **In-Progress Readings** button at the bottom of the Readings screen to see the In-Progress Readings dialog window with the reading status (Figure 68).

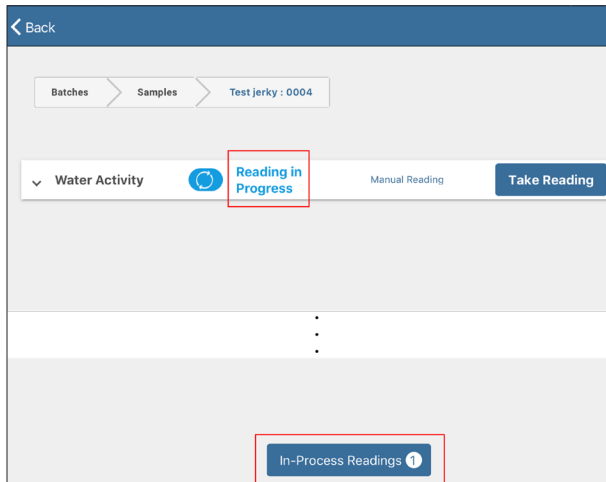

Figure 68 Reading in progress indicator

The In Progress Readings popup window will appear (Figure 69).

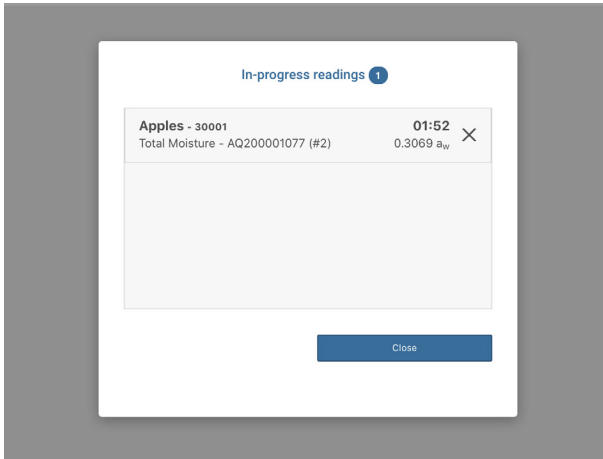

Figure 69 In Progress Reading popup window

12. Select the **Close** button to close the In-Progress dialog window and return to the readings window (Figure 69).
13. When the reading is finished, a dialog box will appear in SKALA Mobile with test details (Table 1).

The AQUALAB 3 indicator light (Figure 70) will turn either a solid green, yellow, or red, indicating the knob should be turned towards the **Open** position. The color signal corresponds to the reading received and should match the result in the SKALA Mobile dialog.

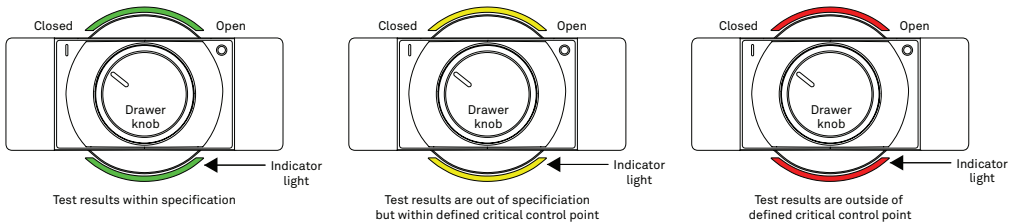
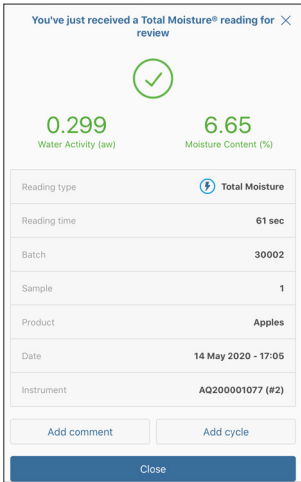

Figure 70 Front-panel indicator light

Table 2 shows the total moisture reading indicators.

Table 2 Completed Total Moisture Reading Indicator



Solid green indicates the reading is within defined operational limits.

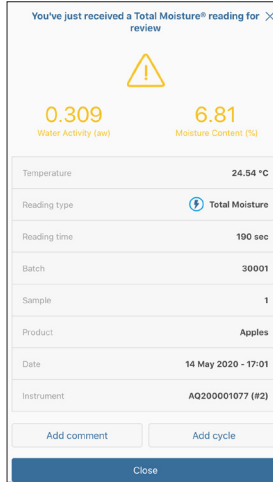

Solid yellow indicates the reading is outside of defined operational limits but within defined fail limits.

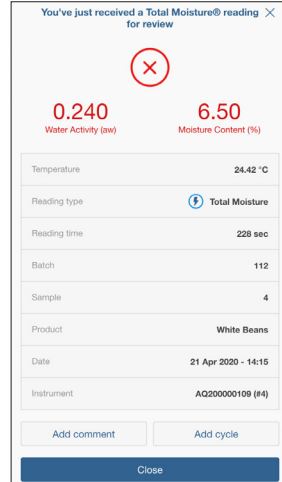

Solid red indicates that the reading is outside of defined fail limits.

See [Troubleshooting](#) for information on what to do if the indicator light is red.

A flashing red indicator light means there is an error associated with the AQUALAB 3. SKALA Mobile should indicate what the error is and how to fix the error. If the error is not actionable by the user, a message will be to contact [Customer Support](#). See [Troubleshooting](#) for information on what to do if the indicator light is red.

14. Turn the drawer knob clockwise and open the drawer.

Information about the product batch and other reading details are automatically saved in SKALA Control. [Figure 71](#) shows old batch readings displayed in SKALA mobile app on the iPad.

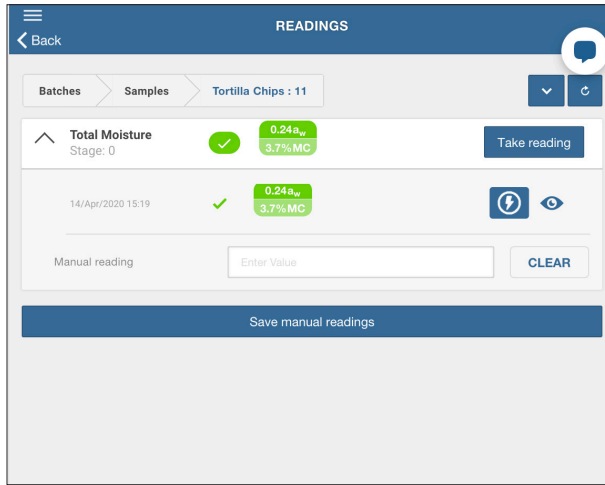

Figure 71 List of completed total moisture readings

The AQUALAB 3 reports the reading when equilibrium is reached; for many products, equilibrium will occur in 5 min or less. However, some types of products may take longer, such as products with

- a moisture barrier (e.g., whole seeds and nuts),
- a high fat content (e.g., peanut butter),
- extremely low water activity, or
- multiple components (e.g., cakes with filling, cheese and crackers, cereal with fruit).

Contact [Customer Support](#) to help determine if the product requires longer read times and if any actions may shorten the read time.

2.5.3 ONE-MINUTE WATER ACTIVITY READING MODE

The One-Minute Water Activity Mode feature enables a reading to complete after 1 min. This feature can be added when a monthly subscription is activated. [Figure 59](#) shows a lightning bolt next to a reading that was taken in one-minute water activity mode. Learn more about SKALA subscription plans and One-Minute Water Activity Reading Mode at metergroup.com/skala-upgrade or contact [Customer Support](#).

3. SYSTEM

This section describes the AQUALAB 3 system.

3.1 SPECIFICATIONS

MEASUREMENT SPECIFICATIONS

Water Activity

Sensor type	Chilled mirror dew point and capacitive hygrometer
Range	0.030–1.000 a_w
Resolution	0.0001 a_w
Accuracy	$\pm 0.005 a_w$ (dew point) $\pm 0.015 a_w$ (capacitance)
Repeatability	0.002 a_w (dew point) 0.010 a_w (capacitance)

Moisture Content

Accuracy	0.1%–0.5% to moisture content reference
Repeatability	0.02%

Operating Temperature

Controlled at constant	25 °C
Resolution	0.1 °C
Accuracy	± 0.1 °C

Read Time

Minimum	60 s (One-Minute Water Activity Mode; subscription required)
Maximum	>200 s (estimated)

PHYSICAL SPECIFICATIONS

Case Dimensions

Length	23.4 cm (9.2 in)
Width	23.4 cm (9.2 in)
Height	12.1 cm (5.0 in)

Case Material

Polycarbonate-ABS (PC-ABS)

Sample Cup Capacity

7.5 mL (0.25 fl oz), partially full, recommended

15 mL (0.51 fl oz), full

Weight

5 kg (11 lb)

Operating Temperature Range

Minimum	15 °C
---------	-------

Typical	NA
---------	----

Maximum	35 °C
---------	-------

Operating Environment

0%–90% noncondensing

Data Communications

USB A to USB B

9,600 baud

Power

110–240 VAC

Reading Duration

Minimum	60 s (One-Minute Water Activity Mode; subscription required)
---------	---

Maximum	>200 s (estimated)
---------	--------------------

COMPLIANCE

Manufactured under ISO 9001:2015

EM ISO/IEC 17050:2010 (CE Mark)

3.2 COMPONENTS

This section describes the components associated with the AQUALAB 3 system.

3.2.1 SENSOR BLOCK

The AQUALAB 3 has been designed around a modular sensor block assembly. This allows the sensor block to be easily replaced—greatly reducing or even eliminating downtime due to annual factory calibration. The sensor block is easily removed from the main instrument chassis by loosening the two thumb screws and removing the ribbon cable. This allows the sensor block to be cleaned ([Section 4.2](#)).

The AQUALAB 3 sensor block contains both a chilled-mirror dew point sensor and a capacitance hygrometer. The chilled-mirror sensor measures the water activity of the equilibrated chamber by cooling the mirror surface until water begins to condense. This is known as the dew point temperature and is a direct measurement of the water activity in the head space. The capacitance hygrometer consists of a hygroscopic porous electrolytic polymer. As water is absorbed, the capacitance of the sensor changes.

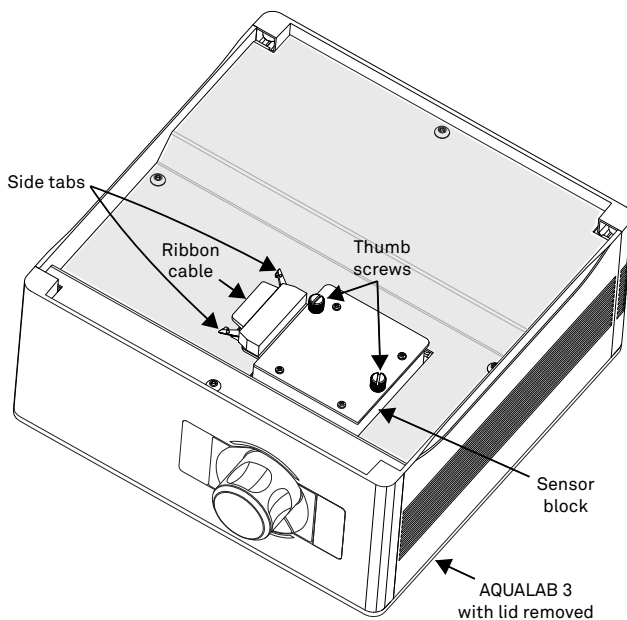

Figure 72 Sensor block in AQUALAB 3

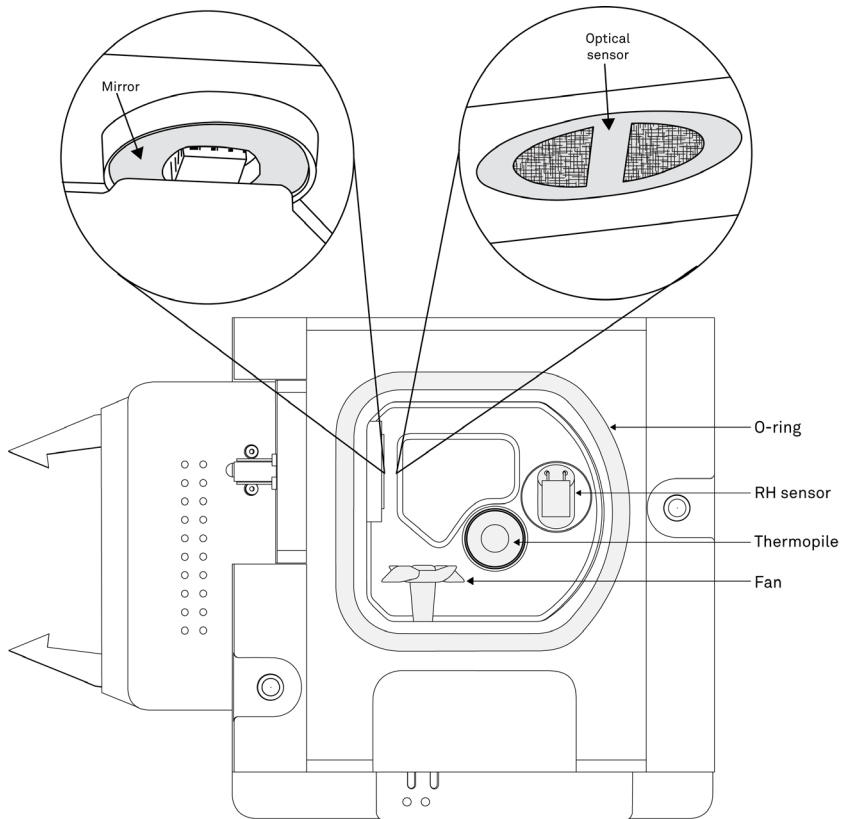

Figure 73 Dual sensor block back view

3.2.2 SAMPLE DRAWER

The AQUALAB 3 sample drawer is removable for easy cleaning and inspection. The sample drawer consists of a sample cover, main drawer assembly, and a metal disk. In order to remove the drawer, the sensor block must first be removed. When removing the drawer, care must be taken to ensure that all of the components are properly reassembled. Failure to do so will compromise subsequent water activity readings.

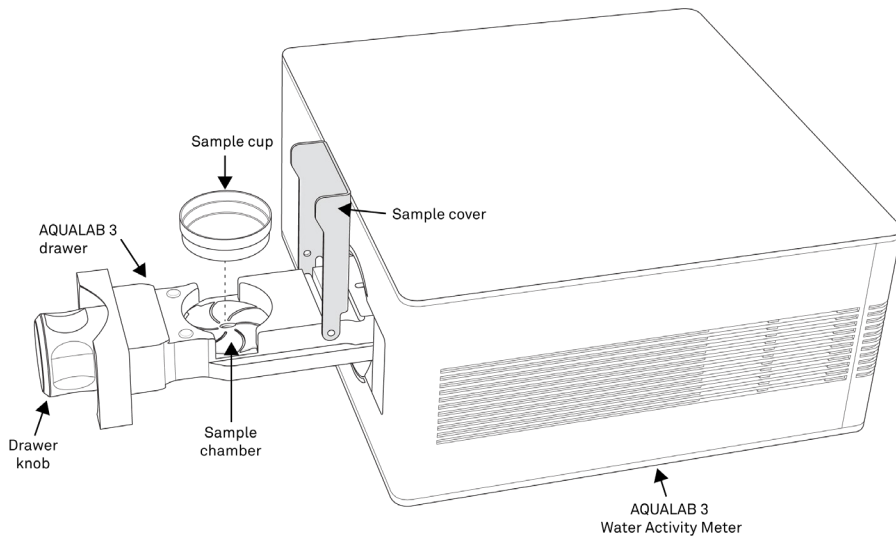

Figure 74 Sample drawer pulled out

3.2.3 DRAWER KNOB INDICATOR LIGHTS

The indicator lights on AQUALAB 3 can provide the user information on the status of the instrument at a glance.

- Solid White—A solid white indicates that the AQUALAB 3 is in standby mode and ready to take a reading.
- Solid Blue—Indicates that the reading has completed and no pass or fail limits were provided.
- Solid Green—Indicates the reading is complete and the measured water activity falls within provided specifications.
- Solid Red—Indicates the reading is complete and the measured water activity falls outside of the provided critical control values.
- Solid Yellow—Indicates that the reading is complete and the measured water activity falls within the required critical operating specifications but outside of desired specifications.
- Blinking Blue—Indicates that a reading is in progress.
- Rotating Blue—Indicates that a reading has been queued and the sample should be loaded and the test started.

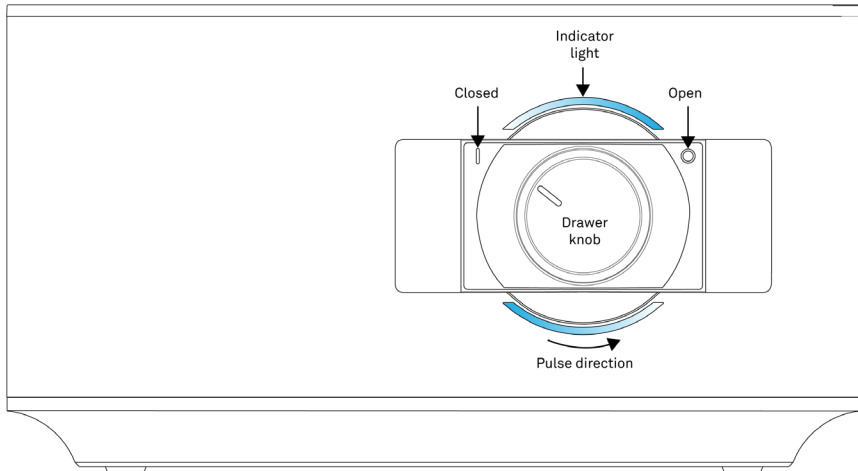

Figure 75 Front knob

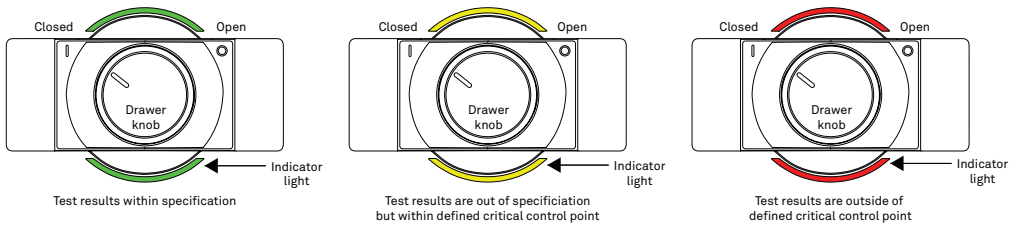

Figure 76 Completed test indicator light options

3.2.4 NEXUS

In order for the AQUALAB 3 to communicate properly with the iPad and SKALA Control, the AQUALAB 3 must be connected to a NEXUS device. Please follow the steps outlined in [Section 2.2](#) to ensure the NEXUS is properly connected and configured.

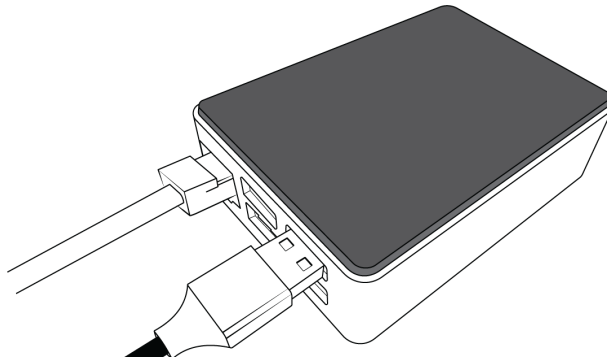

Figure 77 NEXUS connections

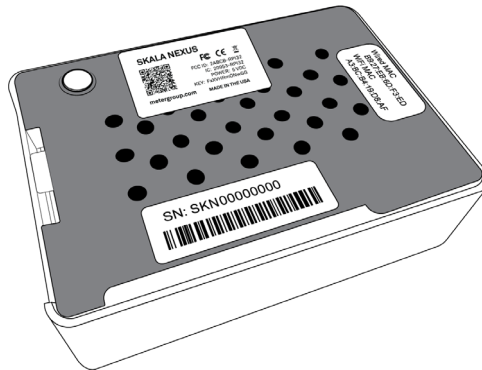

Figure 78 NEXUS back view with labels

3.3 MODES AND TESTS

This section describes the One-Minute Water Activity Mode and additional test types available with a monthly subscription. For more information or to upgrade an AQUALAB 3 to be able to use the One-Minute Water Activity mode or additional tests, please go to metergroup.com/skala-upgrade or contact [Customer Support](#).

3.3.1 ONE-MINUTE WATER ACTIVITY MODE

With a monthly subscription, AQUALAB 3 will run in One-Minute Water Activity mode on the fourth and subsequent readings of that product. The One-Minute Water Activity mode uses a proprietary algorithm that predicts the final water activity based on product specific data collected and stored in SKALA. In most cases, this reading will complete in 1 min.

A product must be properly set up, including having correct target limits defined, within the SKALA Mobile app to generate a one-minute water activity reading. Three consecutive readings must be taken for a new product before the one-minute water activity mode is

activated. Once the first three readings have been taken, all following readings for that product will be in one-minute mode. One-Minute Water Activity readings cannot be taken when operating offline. Review [Section 2.3](#), [Section 2.4](#), and [Section 2.5](#) for instructions on how to set up products, batches, and take water activity readings.

3.3.2 TOTAL MOISTURE

Traditionally, companies are used to just getting half of the moisture picture by only measuring moisture content. Measuring and knowing just moisture content gives yield and some vague quality data. By also knowing moisture energy (water activity) product high-resolution quality and safety information, such as how it relates to lipid oxidation, browning, caking, and clumping, will be available. Knowing the water activity, not the moisture content, allows the user to pinpoint the difference between crisp and stale.

With the invention of the AQUALAB 3, food manufacturers can get both moisture content and water activity in 1 min, which gives them the total moisture picture, product yield, quality, and safety. This allows food manufacturers to decrease rework/waste and increase product consistency and make a significant business impact.

3.4 THEORY

Water is a major component of foods, pharmaceuticals, and cosmetics and influences the product texture, appearance, flavor, and shelf life. Quantifying these attributes require two basic types of water analysis: moisture content and water activity (a_w).

3.4.1 WATER CONTENT

Water activity (a_w) is a measurement of the energy status of the water in a system. The value indicates how tightly water is bound, structurally or chemically, within a substance. The lower a sample's water activity, the more tightly bound that water is within the sample. The concept of water activity is of particular importance in determining product quality and safety. It predicts safety and stability with respect to microbial growth, chemical and biochemical reaction rates, and physical properties.

Water activity is a measure of the energy status of the water in a system and is a far better indicator of product stability than moisture content. The figure below shows how the relative activity of microorganisms, lipids, and enzymes relate to water activity. While other factors, such as nutrient availability and temperature, can affect the relationships, water activity is the best single measure of how water affects these processes.

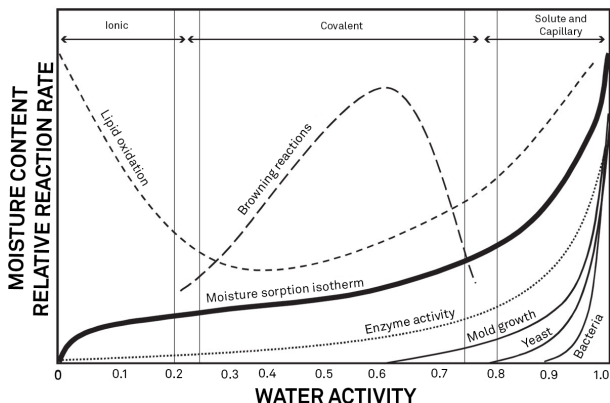

Figure 79 Water activity diagram adapted from Labuza (1976)

3.4.2 MOISTURE CONTENT

Moisture content implies a quantitative analysis to determine the total amount of water present in a sample. There are two primary methods for determining moisture content: loss on drying and Karl Fisher titration. Secondary methods, such as near infrared (NIR) and nuclear magnetic resonance (NMR), may also be used. Moisture content determination is essential in meeting product nutritional labeling regulations, specifying recipes, and monitoring processes.

However, moisture content alone is not a reliable indicator for predicting microbial responses and chemical reactions in materials. The limitations of moisture content measurement are attributed to differences in the intensity that water associates with other components.

Researchers measure the water activity of a system by equilibrating the liquid phase water in the sample with the vapor phase water in the headspace and measuring the relative humidity of the headspace. In the AQUALAB 3, a sample in a sample cup is sealed inside the sample chamber, which contains a fan, a dew point sensor, and an infrared thermometer. The fan speeds equilibrium and controls the boundary layer conductance of the dew point sensor. The dew point sensor measures the dew point temperature of the air in the chamber, and the infrared thermometer measures the sample temperature. From these measurements, the relative humidity of the headspace is computed as the ratio of the dew point temperature saturation vapor pressure to the saturation vapor pressure at the sample temperature. When the water activity of the sample and the relative humidity of the air are in equilibrium, the measurement of the headspace humidity gives the water activity of the sample. Water activity is the relative humidity of air in equilibrium with a sample in a sealed chamber.

In addition to equilibrium between the liquid phase water and the vapor phase, the internal equilibrium of the sample is important. If a system is not at internal equilibrium, one might measure a steady vapor pressure (over the period of measurement) that is not the true water activity of the system. An example of this might be a baked good or a multicomponent food. Initially out of the oven, a baked good is not at internal equilibrium; the outer surface is at

a lower water activity than the center of the baked good. One must wait a period of time in order for the water to migrate and the system to come to internal equilibrium. It is important to keep in mind that by this definition, water activity is an equilibrium measurement.

The water activity of a sample is influenced by factors that affect the binding of water. These factors include temperature, osmotic, matric, and pressure effects. Typically, water activity is measured at atmospheric pressure, so only the osmotic, temperature, and matric effects are important.

TEMPERATURE EFFECTS

Temperature plays a critical role in water activity determination. Most critical is the measurement of the difference between sample and dew point temperature. For water activity measurements to be accurate to 0.001, temperature difference measurements need to be accurate to 0.017 °C. The AQUALAB 3 infrared thermometer measures the difference in temperature between the sample surface and the sample block. The thermometer is carefully calibrated to minimize temperature errors; however, achieving 0.017 °C accuracy is difficult when temperature differences are large. Most accurate measurements are obtained when the sample is near sample chamber temperature.

Another effect of temperature on water activity occurs when samples are near saturation. A sample that is close to 1.0 a_w and is warmer than the sensor block will cause water to condense within the chamber. This causes errors in the measurement and in subsequent measurements until the condensation disappears. For example, a sample at 0.75 a_w only needs to be 4 °C above the sample chamber temperature to cause condensation to form. The AQUALAB 3 warns the user if a sample temperature is more than 4 °C above the chamber temperature, but for high water activity samples, the operator needs to be aware that condensation can occur if a sample is warmer than the sample block.

There are several advantages in having a temperature-controlled water activity meter. A few major reasons are detailed here.

1. Research purposes.

Researchers can use temperature control to study the effects of temperature on the water activity of a sample, make a comparison of the water activity of different samples independent of temperature, and conduct accelerated shelf-life studies or other water activity studies where temperature control is critical. There are many shelf-life, packaging, and isotherm studies in which temperature control would be very beneficial.

2. Compliance with government or internal regulations for specific products.

Though the water activity of most products varies by less than ± 0.02 per degree Celsius, some regulations require measurement at a specific temperature. The most common specification is 25 °C, though 20 °C is sometimes indicated.

3. Minimization of extreme ambient temperature fluctuations.

If the environmental and AQUALAB 3 temperatures fluctuate by as much as ± 5 °C daily, water activity readings may vary by $\pm 0.01 a_w$. Temperature control eliminates variations caused by changes in ambient conditions.

OSMOTIC EFFECTS

Osmotic effects are well known from biology and physical chemistry. Water is diluted when a solute is added. If this diluted water is separated from pure water by a semipermeable membrane, water tends to move from the pure water side through the membrane to the side with the added solute. If sufficient pressure is applied to the solute-water mixture to just stop the flow, this pressure is a measure of the osmotic potential of the solution. Addition of 1 mol of an ideal solute to 1 kg of water produces an osmotic pressure of 22.4 atm. This lowers the water activity of the solution from 1.0 to 0.98 a_w . For a given amount of solute, increasing the moisture content of the systems dilutes the solute, decreasing the osmotic pressure, and increasing the water activity. Since microbial cells are high concentrations of solute surrounded by semipermeable membranes, the osmotic effect on the free energy of the water is important for determining microbial water relations and therefore microbe activity.

MATRIX EFFECTS

The sample matrix affects water activity by physically binding water within its structure through adhesive and cohesive forces that hold water in pores and capillaries and to particle surfaces. If cellulose or protein were added to water, the energy status of the water would be reduced. Work would need to be done to extract the water from this matrix. This reduction in energy status of the water is not osmotic, because the cellulose or protein concentrations are far too low to produce any significant dilution of water. The reduction in energy is the result of direct physical binding of water to the cellulose or protein matrix by hydrogen bonding and van der Waals forces. At higher water activity levels, capillary forces and surface tension can also play a role.

CHILLED-MIRROR DEW POINT LIMITATIONS

The limitation of the AQUALAB 3 is its ability to accurately measure samples with high concentrations (typically >1%) of certain volatile compounds such as ethanol or propylene glycol, which can condense on the surface of the chilled mirror. The extent of the effect is determined by how readily the material volatilizes, which is both concentration and matrix dependent. Therefore, even if a sample contains materials that could volatilize, it may still be possible to make accurate readings using the chilled-mirror dew point sensor. The AQUALAB 3 provides a solution for products containing volatile materials. The AQUALAB 3 uses a tunable diode laser which shines light of a controlled wavelength, specific to water vapor, at a detector that receives light from the laser. The vapor pressure of the headspace of the instrument in equilibrium is determined by the loss of signal strength from the laser caused by the presence of water vapor in the headspace. For more information, contact [Customer Support](#).

SORPTION ISOTHERMS

Changes in moisture content affect both the osmotic and matrix binding of water in a product. Thus, a relationship exists between the water activity and moisture content. This relationship is called the sorption isotherm and is unique for each product. Besides being unique to each product, the isotherm changes depending on whether it was obtained by

drying or wetting the sample. Typically, large safety margins are built into moisture content specifications to allow for these uncertainties.

While the sorption isotherm is often used to infer water activity from moisture content, one could easily go the other direction and infer moisture content from water activity. This is particularly attractive because water activity can be measured much more quickly than moisture content. This method gives particularly good precision in the center of the isotherm. In order to infer moisture content from water activity, an isotherm for the particular product is needed. METER sells an isotherm generator called the AQUALAB Vapor Sorption Analyzer (VSA) or METER can run the isotherm for a fee. Visit metergroup.com/food/services/water-activity-and-isotherm-testing for more information.

For example, if using the AQUALAB 3 to monitor the moisture content of dried potato flakes, measure the water activity and moisture content of potato flakes dried to varying degrees using the standard drying process for those flakes. That data is used to construct an isotherm and infer the moisture content using the measured water activity of samples and that isotherm.

4. SERVICE

This section contains performance verification, cleaning and maintenance guidelines, troubleshooting guidelines, customer support contact information, and terms and conditions.

4.1 PERFORMANCE VERIFICATION

Verification tests to validate instrument accuracy should be performed once per day or once per shift when the AQUALAB 3 is in use. Verification schedules and the selection of verification standards to use are set in SKALA Control.

The best way to verify the AQUALAB 3 is to use a technique called bracketing, which uses the verification standards of the closest higher and lower values to the expected water activity of the product. If measuring a cookie that typically has a water activity of $0.600 a_w$, use the $0.500 a_w$ and $0.760 a_w$ standards to verify. If measuring milk powder with $0.300 a_w$, use the $0.250 a_w$ and $0.500 a_w$ standards to verify. SKALA Mobile will display prompts to run a verification according to the set schedule and using the specified standards.

When SKALA Mobile indicates a verification is needed, perform a manual verification. Follow the steps listed below.

1. Wash hands thoroughly or put on lab gloves.
2. Prepare standard.

NOTE: The standard should be prepared outside of the sample chamber to avoid contaminating the chamber by spilling standard.

- a. Check the expiration date of the standards solution.
- b. The typical shelf life of standards is 18 months. Expired standards should not be used for verification.
- c. Read the standards in the order of increasing water activity if using more than one standard.
- d. Remove the cap on the standard vial by twisting counter clockwise.
- e. Empty the vial contents into a sample cup.
- f. The standard should cover the bottom of the cup.
- g. Place the standard cup in the sample chamber.
- h. Close the sample drawer and turn the knob to the left to lock the drawer.

NOTE: Do not contaminate the sample chamber by spilling standard inside the sample chamber.

3. In the SKALA mobile app, navigate to the Instruments page.
4. Select VERIFY located at the far right of the AQUALAB 3 line (Figure 80).

The Instrument Verification dialog window will appear (Figure 81). This section contains information on taking water activity readings.

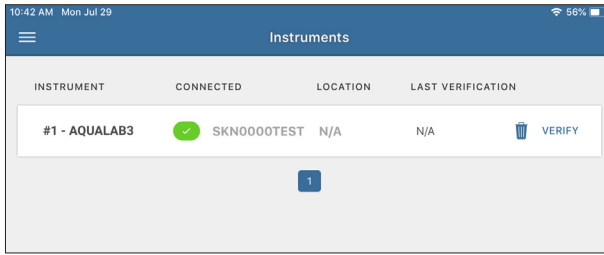

Figure 80 Instrument online and visible to NEXUS

5. Follow the directions on the Clean Device tab to make sure the sample drawer and sensor block are clean (Section 4.2).

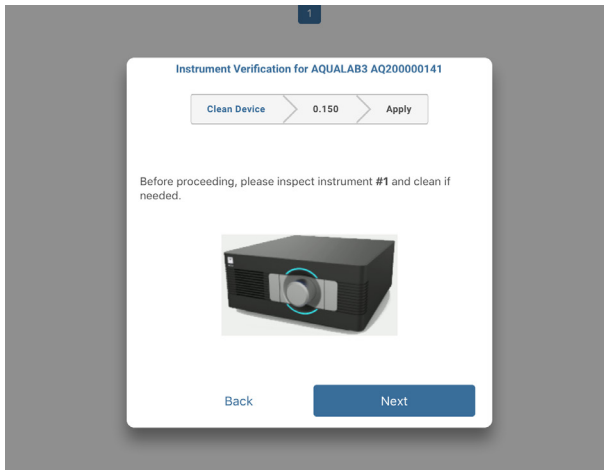

Figure 81 Verify correct instrument

6. Select the **Next** button.

The standard tab will appear (Figure 82). The tab heading will show the selected standard for the verification test.

If an error message indicates there are no assigned standards for the instrument, go to skalacontrol.com and select a standard to use.

SERVICE

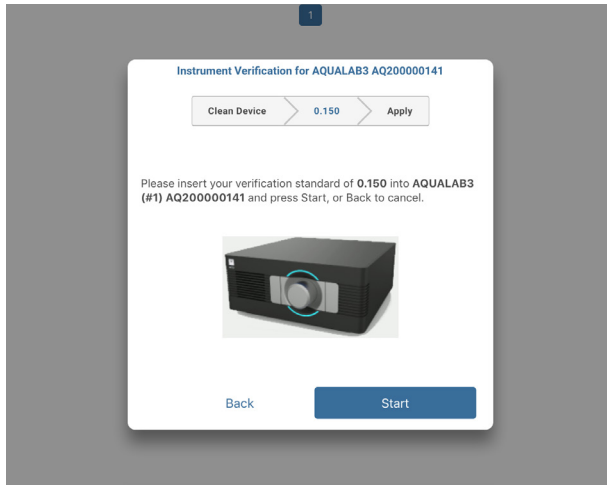

Figure 82 Verify correct standard

7. Insert the standard in the sample chamber.
8. Close the sample cover.
9. Push the sample drawer in.
10. Turn the drawer knob counter-clockwise (left) to close the drawer.
11. Select the **Start** button on the SKALA Mobile app screen to start the reading.
12. Select the **In-Process Readings** button at the bottom of the Take a Reading window to see the progress of readings (Figure 83).

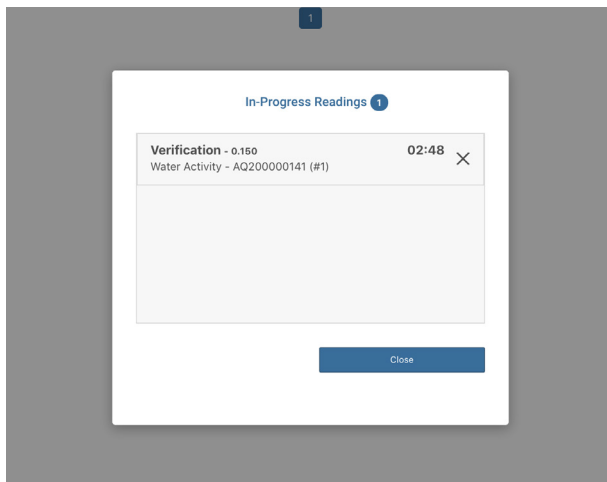



Figure 83 In-Progress Reading screen

When the verification reading is finished, a dialog window will appear in SKALA Mobile with the results of the reading (Table 3).

Table 3 Completed Verification Reading Indicator

You've just received a Reading for Review ×



Within Spec

Reading Type	Water Activity
Value	0.271 a_w
Batch	0004
Sample	1
Product	Test jerky
Date	29 Jul 2019 - 10:52
Instrument	AQ200000141 (#1)



Add Comment (Optional) Save

If the reading is within $\pm 0.005 a_w$ of the standard value, the calibration has been verified, and the AQUALAB 3 is ready to begin taking readings.

You've just received a Reading for Review ×

Outside of Operating Limits
Reading must be between 0.1 and 0.9

Reading Type	Water Activity
Value	0.998 a_w
Batch	11-02Aug191635
Sample	1
Product	TEST002AW
Date	02 Aug 2019 - 16:40
Instrument	AQ200000134 (#7)

Add Comment  Add Cycle 

Submit



If the reading is more than $\pm 0.005 a_w$ but less than ± 0.03 of the standard value, the user will be asked if an offset should be applied.

Apply an offset only if the instrument has been cleaned thoroughly prior to running a verification.

You've just received a Reading for Review ×

Outside of Fail Limits
Reading must be between 0.5 and 0.6

Reading Type	Water Activity
Value	1.002 a_w
Batch	11-02Aug191641
Sample	1
Product	TT001
Date	02 Aug 2019 - 16:51
Instrument	AQ200000134 (#7)

Add Comment  Add Cycle 

Submit

If the reading is more than $\pm 0.03 a_w$ of the standard value, SKALA mobile app will display instructions to clean the AQUALAB 3 and retry the verification.

If the value consistently fails (is greater than $\pm 0.03 a_w$ out of specification) with the correct standard, contact [Customer Support](#) for assistance.

A flashing red indicator light means there is an error associated with the AQUALAB 3. SKALA Mobile should indicate what the error is and how to fix the error. If the error is not actionable by the user, a message will be to contact [Customer Support](#).

4.2 CLEANING

It is extremely important to keep the instrument clean to make sure it is performing accurately. It should be cleaned when contamination is seen. However, some types of contamination are not visible. The best way to check for contamination is by running verification standards daily or at the start of each shift. If the verification standards are not within specification, cleaning the AQUALAB 3 sensor block is recommended. The AQUALAB 3 comes with a cleaning kit that contains the following items:

SERVICE

- Cleaning swabs
- KIMWIPES strips (1.25 in)
- Cleaning solution (in bottle with white lid)
- Deionized water (in bottle with blue lid)

NOTE: Regulations regarding hazardous materials prevent METER from shipping isopropyl alcohol in the cleaning kits, but it is often the best cleaning agent, particularly when measuring samples with a high fat content.

Use the following process to clean the AQUALAB 3.

1. Power off the AQUALAB 3 and disconnect the SKALA NEXUS.
2. Put on lab gloves.
3. Wipe the drawer and detachable sample cover clean, making sure that no sample residue remains.

Ensure that the sample cover and drawer are thoroughly dried prior to measurement.

4. Lift off the top of the AQUALAB 3 to expose the interior.

Only the sensor block and ribbon cable will be visible.

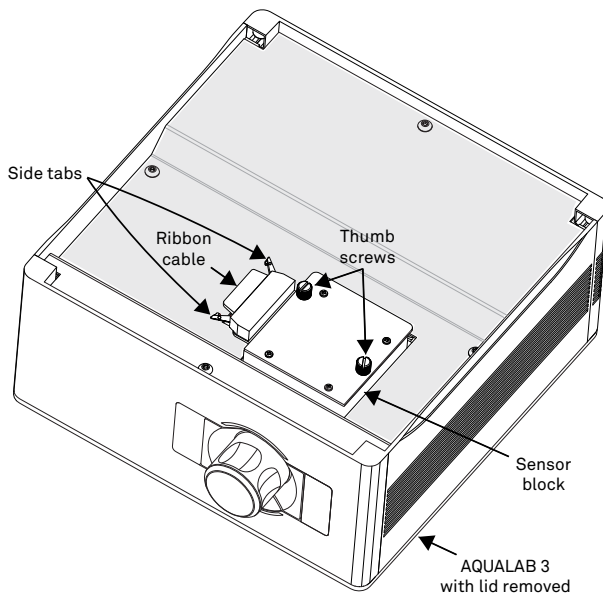

Figure 84 Sensor block in AQUALAB 3

5. Pull out on the side tabs to unplug the ribbon cable (Figure 84).
6. Loosen the thumbscrews and lift sensor block to remove (Figure 85).

NOTE: The block has been designed to be ESD resistant, however, care should be taken when cleaning and handling the AQUALAB 3 block.

AQUALAB 3

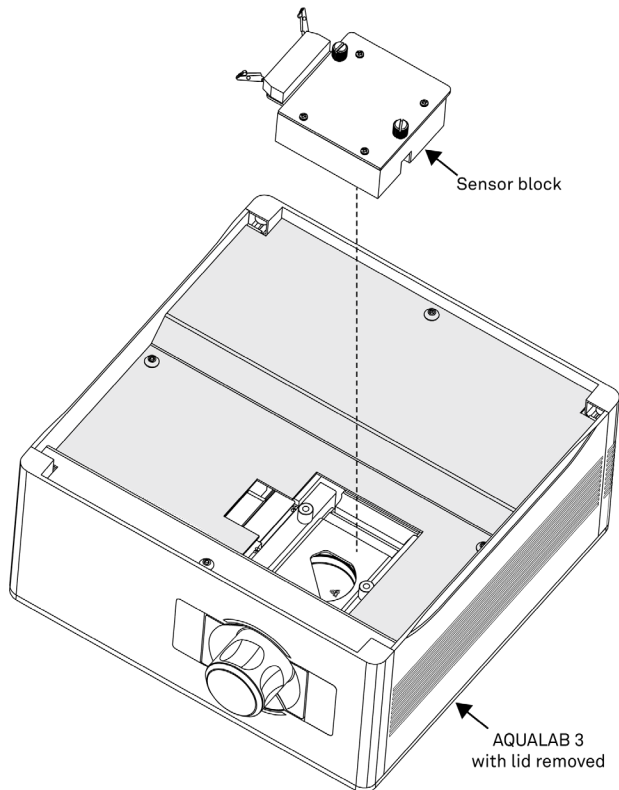

Figure 85 Remove sensor block

7. Turn the sensor block over so the sensor chamber area is visible, and clean the sensors and sensor block ([Figure 86](#)).
 - a. Wrap a KIMWIPES strip around a cleaning swab by folding the wipe over the head and twisting the swab until reaching the end of the strip.

View the [AQUALAB Cleaning Kit](#) video showing how to wrap a KIMWIPES strip around the cleaning swab.

NOTE: Cover the cleaning swab completely with the tissue to avoid scratching the components and surface of the chamber.
 - b. Moisten the KIMWIPES strip with some cleaning solution or isopropyl alcohol (concentration greater than 90% recommended).

To avoid contamination, do not dip a used KIMWIPES strip into the cleaning solution or alcohol.
 - c. Clean the mirror, optical sensor, and thermopile by gently wiping the KIMWIPES strips over the sensors.

Do not put too much pressure on the thermopile sensor, the mirror, or optical sensor.

Discard used KIMWIPES strips frequently during the cleaning process to get each component clean.

NOTE: Use the KIMWIPES strips supplied in the cleaning kit rather than facial tissue, paper towels, or commercial swabs. KIMWIPES strips are specially made for lab work. They do not contain adhesives or other contaminants and are made from low-lint fibers that will not scratch delicate surfaces when wet.

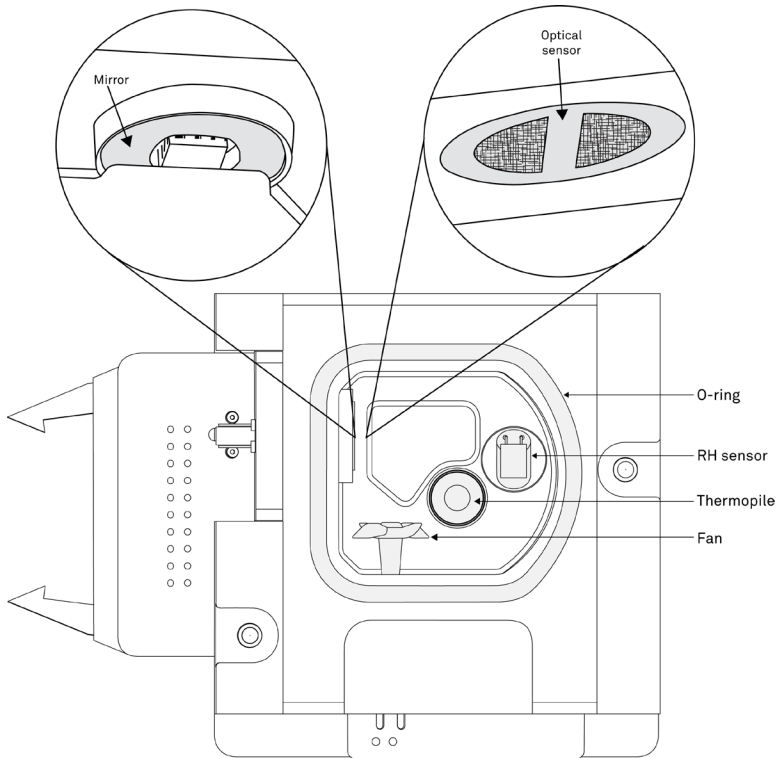

Figure 86 View of inside of removed sensor block

8. With additional moistened KIMWIPES strips, clean the remaining surfaces of the sensor block without wiping the KIMWIPES strips back over the sensors.
9. Moisten a fresh KIMWIPES strip wrapped around the cleaning swab with deionized water.
10. Clean the sensors and sensor block, following the same procedure outlined in [step 7](#). To avoid cross-contamination, do not dip used KIMWIPES strips into clean distilled water.
11. Use fresh dry KIMWIPES strips wrapped around the cleaning swab to remove moisture on the sensors and in the sensor block.

4.3 TROUBLESHOOTING

[Table 4](#) lists common problems and their solutions. If the problem is not listed or these solutions do not solve the issue, contact [Customer Support](#).

Table 4 Troubleshooting the AQUALAB 3 System

Problem	Possible Solutions
<p>No AQUALAB 3 available in the app when trying to take reading.</p>	<p>Make sure the AQUALAB 3 is properly connected to all wires and the power indicator is in the ON position.</p> <p>Make sure the NEXUS is properly connected to all wires and the power indicator light is ON.</p> <p>Make sure the iPad and NEXUS are connected to the same local area network (LAN).</p> <div style="display: flex; justify-content: space-around;"> <div data-bbox="390 371 735 679"> <p>Figure 87 No available instruments</p> </div> <div data-bbox="753 371 1112 679"> <p>Figure 88 No NEXUSES found</p> </div> </div> <p>Disconnect and reconnect the NEXUS and the AQUALAB 3 to reboot them. Wait a few minutes for the NEXUS to reestablish an Ethernet connection.</p> <p>If the AQUALAB 3 still does not appear, contact Customer Support.</p>
<p>The device is not reading correctly.</p>	<p>Make sure that clean sampling practices Cleaning are being followed and that standards solutions have not expired.</p> <p>Check if the product being tested has special properties that need special consideration. Volatile compounds will affect the water activity readings of the AQUALAB 3. If products being tested contain volatiles, contact Customer Support for further assistance.</p> <p>Verify that the o-ring is seated properly by removing the sensor block and inspecting it.</p>
<p>There are no assigned standards for instrument verification. Please assign a standard to the instrument in SKALA Control, and try again.</p>	<p>Go to skalacontrol.com and select a standard to use in verification of the instrument.</p>
<p>AQUALAB 3 indicator light is red.</p>	<p>Instrument needs to be calibrated. Contact Customer Support for more information.</p>

4.4 CUSTOMER SUPPORT

NORTH AMERICA

Customer service representatives are available for questions, problems, or feedback Monday through Friday, 7:00 am to 5:00 pm Pacific time.

Email: support.food@metergroup.com
sales.food@metergroup.com
support.skala@metergroup.com

Phone: +1.509.332.5601

Fax: +1.509.332.5158

Website: metergroup.com

EUROPE

Customer service representatives are available for questions, problems, or feedback Monday through Friday, 8:00 to 17:00 Central European time.

Email: support.europe@metergroup.com
sales.europe@metergroup.com

Phone: +49 89 12 66 52 36

Fax: +49 89 12 66 52 20

Website: metergroup.de

If contacting METER by email, please include the following information:

Name	Email address
Address	Instrument serial number
Phone	Description of the problem

NOTE: For products purchased through a distributor, please contact the distributor directly for assistance.

4.5 TERMS AND CONDITIONS

By using METER instruments and documentation, you agree to abide by the METER Group, Inc. USA Terms and Conditions. Please refer to metergroup.com/terms-conditions for details.

REFERENCES

Labuza, Ted P., K. Acott, S. R. Tatini, R. Y. Lee, J. Flink, and W. McCall (1976). "Water activity determination: A collaborative study of different methods." *Journal of Food Science* 41, no. 4: 910–917.

METER Group, Inc. USA

2365 NE Hopkins Court Pullman, WA 99163
T: +1.509.332.2756 F: +1.509.332.5158
E: info@metergroup.com W: metergroup.com

METER Group AG

Mettlacher Straße 8, 81379 München
T: +49 89 1266520 F: +49 89 12665220
E: info.europe@metergroup.com W: metergroup.de

